

Table of Contents

5.0	Table of Contents
5.1	System description
5.100	General
5.110	System structure
5.115	FLEXWELL® district heating cable range
5.2	Planning, design engineering
5.200	Pressure loss chart
5.210	Heat losses
5.3	Components
5.300	T-joint
5.305	Through connection, PN 16, types 30/91 to 147/220
5.310	Through connection, PN 25, types 30/91 to 200/310, welded
5.315	Through connection, PN 25, types 30/91 to 75/171, GR version
5.320	Connector, PN 16, types 98/171 to 147/220, versions A and DE
5.325	Connector, PN 16, types 30/91 to 200/310, G version, welded
5.330	Wall leadthrough
5.335	Wall leadthrough with core bore or fiber cement liner pipe (impermeable to pressure from water)
5.340	Wall leadthrough with steel sheath pipe (impermeable to pressure from water)
5.345	Sheath pipe entry (impermeable to pressure from water)
5.350	House entry bend
5.5	Underground construction, installation
5.500	Loop-in method, type of routing/installation
5.505	Loop-in method, building entries
5.510	Dimensions for axis and wall distances, connector types 30/91 to 75/171
5.515	Dimensions for axis and wall distances, connector types 98/171 to 147/220
5.520	Dimensions for axis and wall distances, welded connector types 30/91 to 200/310
5.525	Installation through protective pipes
5.530	Installation through protective pipes
5.535	Horizontal directional drilling (HDD) method
5.540	Installation without trenches
5.545	Information for underground construction – technical regulations, standards, information on execution
5.550	Information for underground construction, trench dimensions
5.555	Information for underground construction, wall openings
5.560	Information for underground construction, core bores
5.565	Information for underground construction, through connection
5.570	Information for underground construction, T-joint – downward branch
5.575	Information for underground construction, T-joint – upward branch
5.580	Information for underground construction, house entry bends
5.585	Distance from other supply lines

System description

1. General

FLEXWELL® district heating cable is the registered name of a flexible pipe system from BRUGG Pipe Systems, used to transport district heat and domestic hot water. This pipe - which is laid directly in the ground - has proven its merits in practice for many years under a wide range of extreme conditions.

FLEXWELL® district heating cable has a helically corrugated inner pipe made of stainless steel. The materials used are extremely resistant to corrosion, making this product ideal for transporting a wide variety of media such as heating water, domestic hot water, drinking water, condensate and others.

The corrugation of the inner pipe not only ensures the flexibility of the whole pipe, but also compensates intrinsically for the temperature-induced change in length. There is no need for precautions to accommodate expansion (U-bends, L-limbs or fixed points) of the sort required with rigid pipe systems.

Thanks to its corrugated outer steel case, FLEXWELL® district heating cable belongs to the steel casing pipe family. The continuous multi-layer anti-corrosion protection on the outside ensures unparalleled security and reliability in the ground during operation.

The thermal insulation of FLEXWELL® district heating cable consists of flexible polyurethane (PUR) rigid foam (CFC-free) which can withstand operating temperatures of up to 150 °C.

The bending capability of FLEXWELL® district heating cable ensures easy adaptation to virtually all pipe routing conditions. It is possible to pass over or under existing supply pipes, and other obstacles can be bypassed. With FLEXWELL® district heating cable, users can choose the shortest pipe route without considering the classical method of pipe construction.

FLEXWELL® district heating cable is a reliable solution, especially when the ground is not very stable and subsidence is possible, and in very wet ground (high groundwater levels). This product can be laid through water (siphon method) with no problems.

Thanks to this product's continuous anti-corrosion protection, the pipe trenches for FLEXWELL® district heating cable can be substantially narrower than for rigid pipe systems. This in turn allows considerable savings on underground construction work.

Because of its flexibility and the high loading capacity of its casing, FLEXWELL® district heating cable is particularly suitable for the horizontal directional drilling (HDD) method. This method is used wherever valuable surfaces require protection or difficult crossings would otherwise have to be constructed.

Taking account of the very short time required for installation, FLEXWELL® district heating cable offers a solution for district heat transport that is not only technically perfect but also very cost-effective, with minimal disruption for district heat customers and the general public during the construction period.

2. Range of applications

Max. permitted operating temp. T_{Bmax} :	-170 to +150 °C
Max. permitted operating pressure p:	PN 25 bar

System description

1. Medium pipe

Materials: Corrugated medium pipe made of nickel chromium steel, X5 CrNi 18-10 (1.4301, AISI 304) or X6 CrNiMoTi 17-12-2 (1.4571, AISI 316Ti) or X2 CrNiMo 17-12-2 (1.4404, AISI 316L)

Requirements: Steel quality to EN 10088

2. Thermal insulation

Materials: CFC-free, flexible polyurethane foam (PUR) with λ_{50} value of 0.032 W/mK, resistant up to 150 °C

PUR insulation	Reference temperature	FHK value	Test standard
Density	-	> 60 kg/m ³	DIN 53420
Thermal conductivity	50 °C	≤ 0.032 W/mK	DIN 52612
Percentage of closed cells	-	≥ 90 %	-
Water absorption after 24 hours	-	≤ 10 %	EN 253

3. CrNi steel casing

Materials: Corrugated steel casing in DC 04, DIN EN 10139 or 1.4512, DIN EN 10088-2

4. Anti-corrosion protection

Materials: Double polymer layer (bitumen-caoutchouc paste)

5. PE-LD protective casing

Materials: Made of polyethylene 2YM2 (PE) to VDE 0209

Purpose: Protection against mechanical actions and humidity

PE-LD protective casing	Reference temperature	Value	Test standard
Density	50 °C	931 kg/m ³	ISO 1183
Thermal conductivity	-	0.43 W/mK	DIN 52612
Crystallite melting range	-	122 °C	ISO 11357-3

6. Monitoring wires

Materials: 1 x NiCr, red, insulated/perforated, Ø 1.1 mm/0.5 mm²
1 x Cu, green, insulated, Ø 1.3 mm/0.8 mm²
1 x Cu, white with nonwoven, Ø 1.55 mm/1.13 mm²

Systems: Conductor pairs: NiCr-red (a) + Cu-green (b) \triangleq WIREM/Brandes system
Cu-green (b) + Cu-white (c) \triangleq Nordic system

Purpose: Identification and location of moisture by means of resistance and pulse measurements

FLEXWELL® district heating cable range

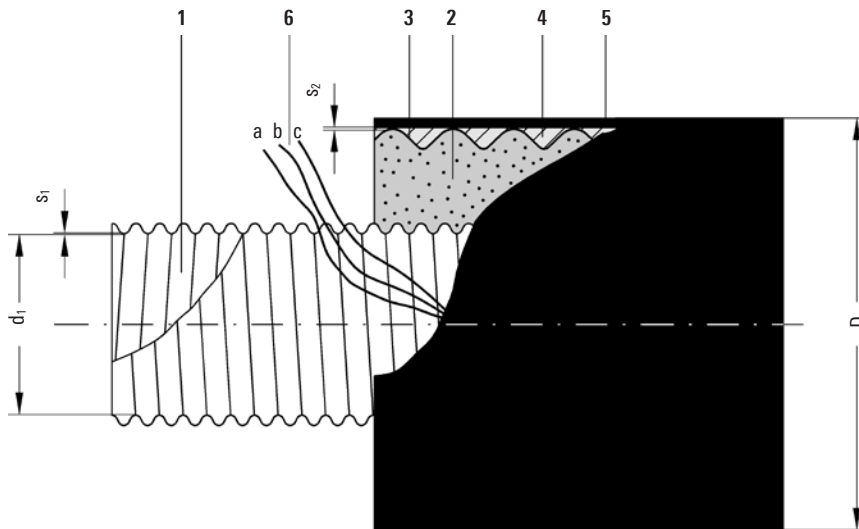

Structure

- 1 Stainless steel carrier pipe
- 2 PUR foam
- 3 Steel casing
- 4 Anti-corrosion protection
- 5 PE-LD casing
- 6 Monitoring wires

FLEXWELL® district heating cable

Type	DN	Carrier pipe $d_1 \times s_1$ mm	Casing pipe s_2 mm	External diameter D mm	Minimum bending radius m	Volume carrier pipe l/m	Weight kg/m	Maximum delivery lengths* m
30/ 91	25	30.0 x 0.3	0.6	94	1.0	0.81	3.9	1000
39/116	32	38.9 x 0.4	0.6	121	1.2	1.35	5.7	640
60/148	50	60.0 x 0.5	0.7	156	1.5	3.12	9.1	590
75/171	65	75.8 x 0.6	0.8	178	2.0	5.12	12.2	480
98/171	80	98.0 x 0.8	0.8	178	2.0	8.43	12.8	480
98/220	80	98.0 x 0.8	0.9	233	4.0	8.43	19.3	270
127/220	100	127.0 x 0.9	0.9	233	4.0	14.30	19.8	270
147/220	125	147.0 x 1.0	0.9	233	4.0	17.30	20.3	270
200/310	150	150.0 x 1.2	1.3	313	5.0	23.20	33.2	250

* based on maximum possible drum capacity and normal production length

Pressure loss chart

Water temperature 80 °C
 (1 mmWS = 9.81 Pa)

$\dot{m} \approx \frac{Q \cdot 860}{\Delta T}$	\dot{m} =	Flow rate in kg/h
	Q =	Power requirement in kW
	ΔT =	Temperature difference VL(flow)/RL(return) in °C

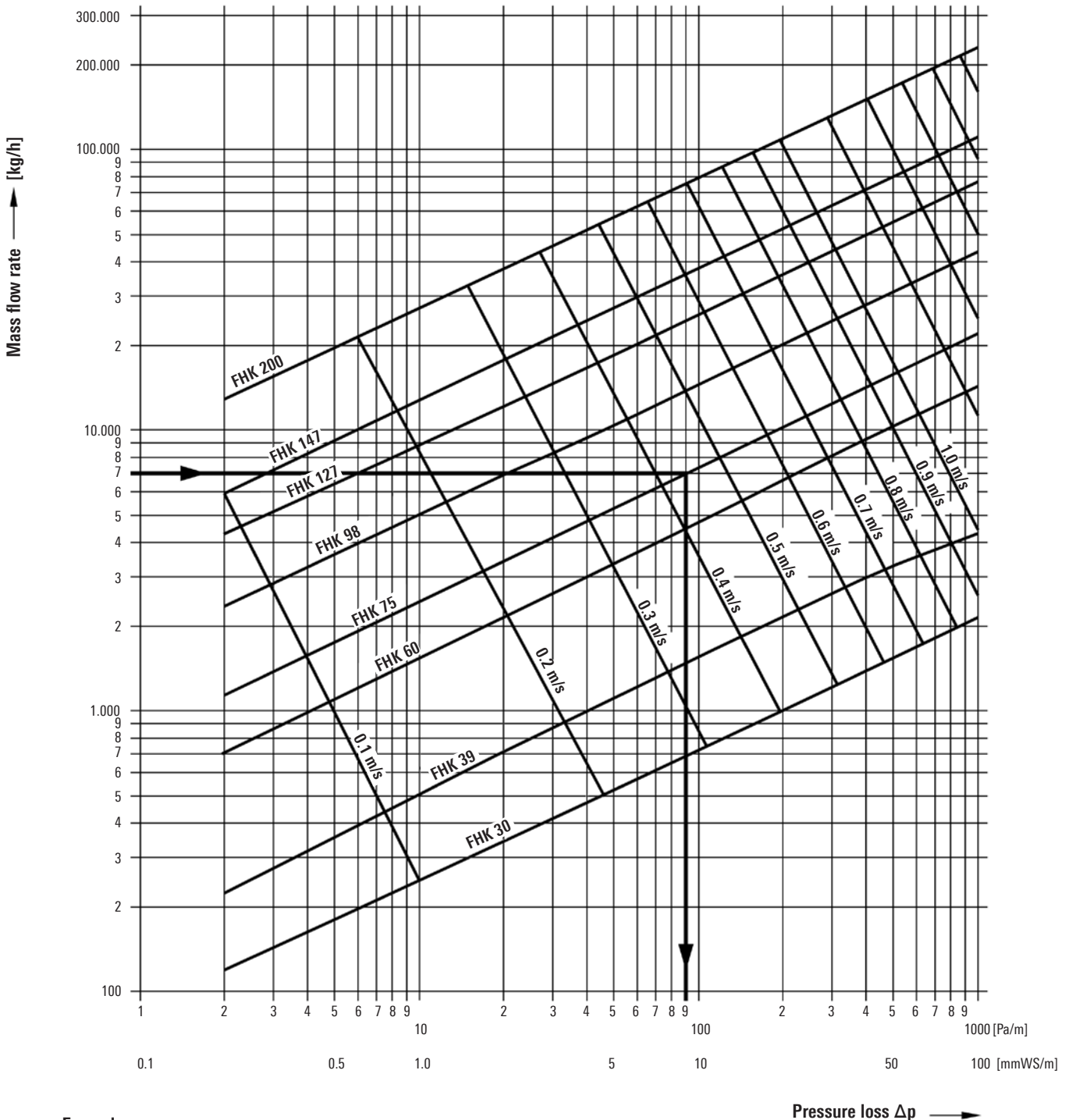

Example:
 Mass flow rate 7000 kg/h; FLEXWELL® district heating cable type 75/171
 → Pressure loss 90 Pa/m

Heat losses

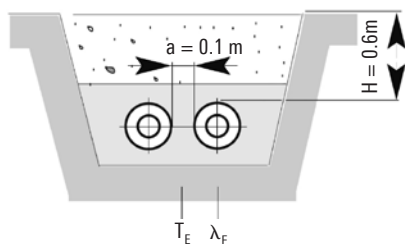
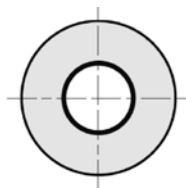

FLEXWELL® district heating cable

Heat losses q [W/m] for one UNO pipe

FHK type	U-value [W/mK]	Average operating temperature T _B [°C]										
		40°	50°	60°	70°	80°	90°	100°	110°	120°	130°	
30/ 91	0.1983	5.95	7.93	9.92	11.90	13.88	15.86	17.85	19.83	21.81	23.80	
39/116	0.1998	5.99	7.99	9.99	11.99	13.99	15.98	17.98	19.98	21.98	23.98	
60/148	0.2384	7.15	9.54	11.92	14.30	16.69	19.07	21.46	23.84	26.22	28.61	
75/171	0.2748	8.24	10.99	13.74	16.49	19.24	21.98	24.73	27.48	30.23	32.98	
98/171	0.4177	12.53	16.71	20.89	25.06	29.24	33.42	37.59	41.77	45.95	50.12	
98/220	0.2643	7.93	10.57	13.22	15.86	18.50	21.14	23.79	26.43	29.07	31.72	
127/220	0.4043	12.13	16.17	20.22	24.26	28.30	32.34	36.39	40.43	44.47	48.52	
147/220	0.5587	16.76	22.35	27.94	33.52	39.11	44.70	50.28	55.87	61.46	67.04	
200/310	0.5585	16.76	22.34	27.93	33.51	39.10	44.68	50.27	55.85	61.44	67.02	

Type of installation, FHK UNO: 2-pipe, laid in the ground
 Pipe distance: a = 0.10 m
 Coverage height: H = 0.60 m
 Ground temperature: T_E = 10 °C
 Soil conductivity: λ_E = 1.2 W/mK
 Conductivity of PUR foam: λ_{PU} = 0.032 W/mK

Heat loss during operation:
 $q = U (T_B - T_E)$ [W/m]
 U = Heat transfer coefficient [W/mK]
 T_B = Average operating temperature [°C]
 T_E = Average ground temperature [°C]

T-joint

Structure of T-joint

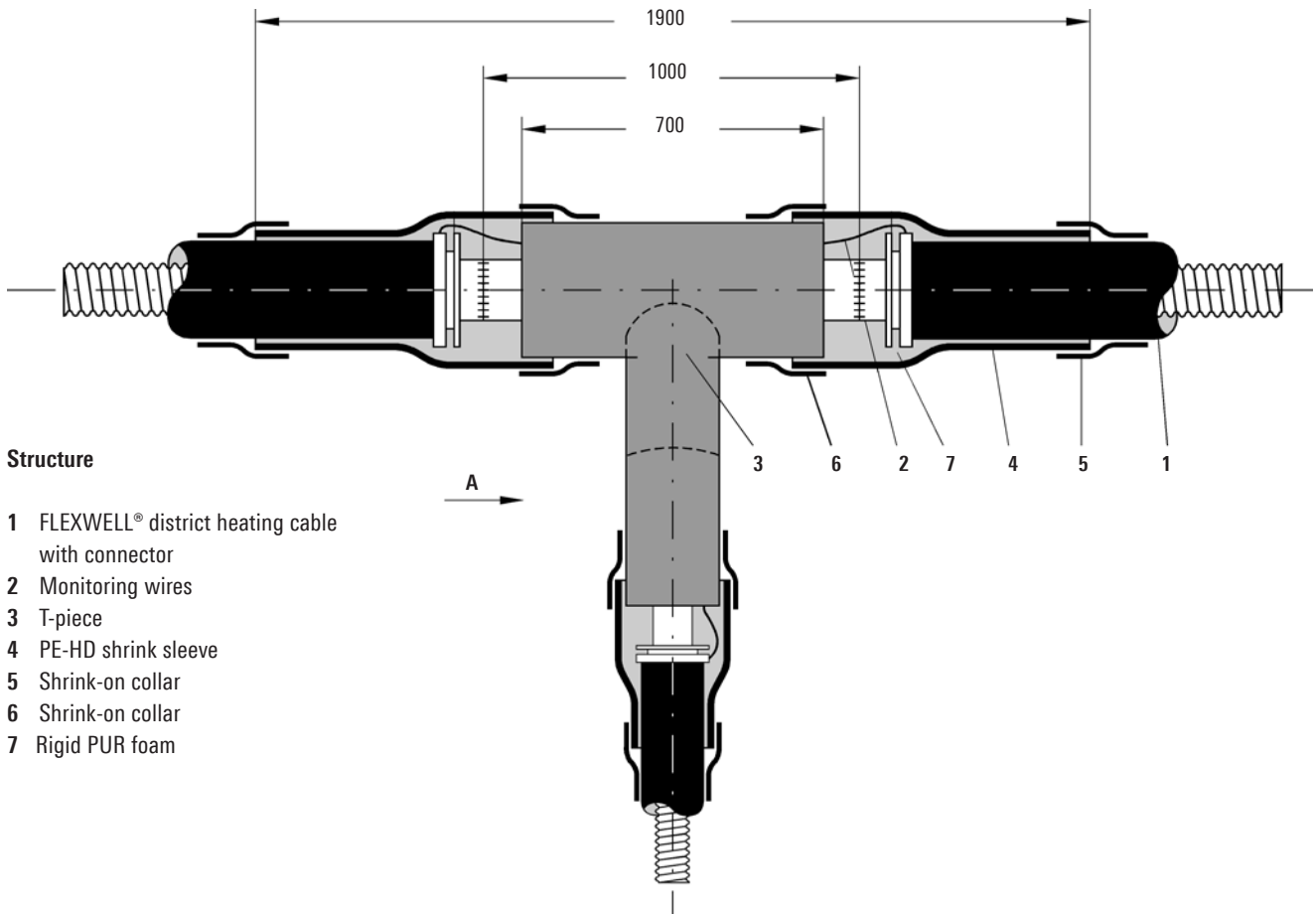

Structure

- 1 FLEXWELL® district heating cable with connector
- 2 Monitoring wires
- 3 T-piece
- 4 PE-HD shrink sleeve
- 5 Shrink-on collar
- 6 Shrink-on collar
- 7 Rigid PUR foam

View A

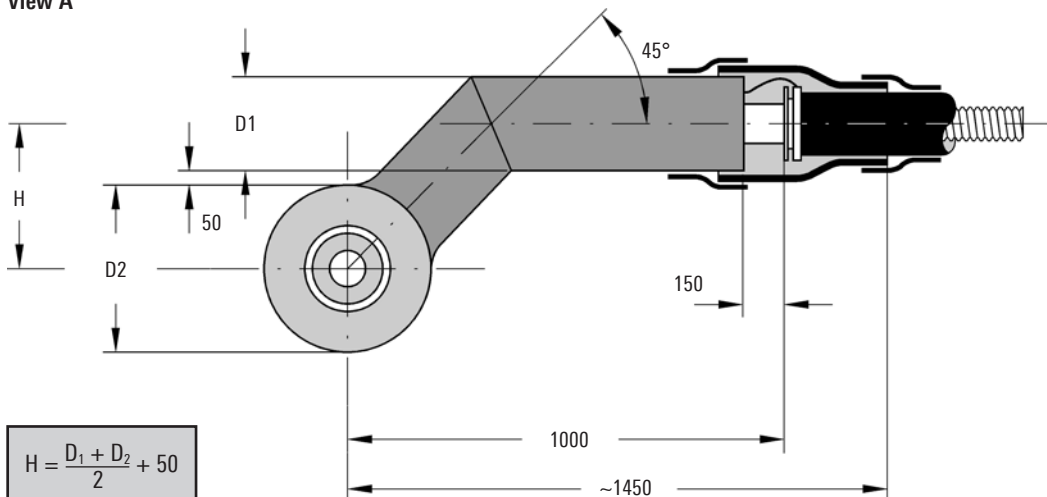

$$H = \frac{D_1 + D_2}{2} + 50$$

Depending on the pressure level, the T-pieces are supplied with either standard or welded connectors.

Figures in mm

Through connection, PN 16

Types 30/91 to 147/220

Structure of through connection, PN 16

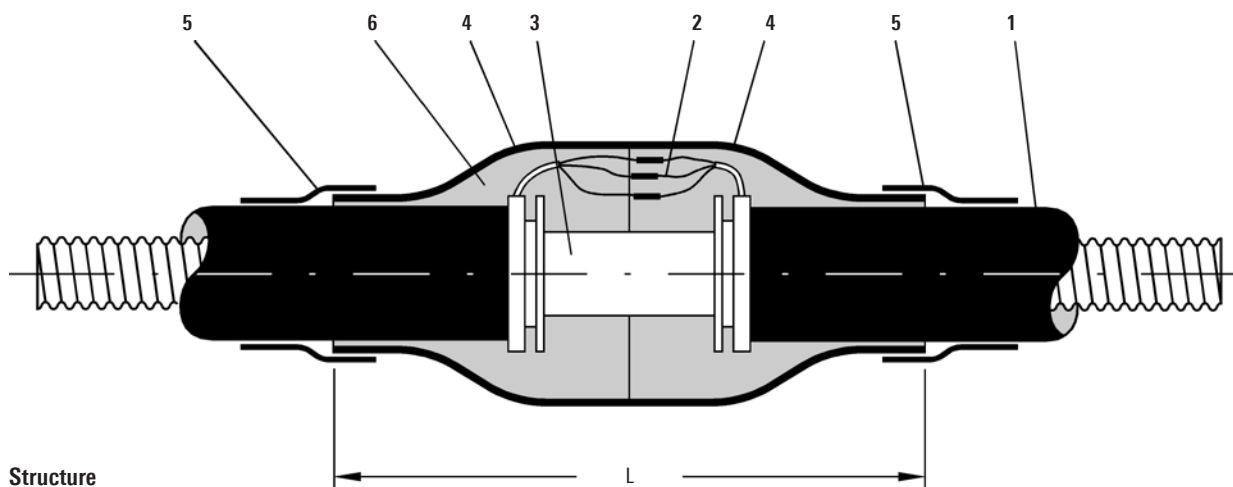

Structure

- 1 FLEXWELL® district heating cable with connector
- 2 Monitoring wires
- 3 Connecting pipe with support sockets
- 4 PE-HD shrink sleeve
- 5 Shrink-on collar
- 6 Rigid PUR foam

Dimensions of through connection

FHK type	L	Ø D _{max}
	mm	mm
30/ 91	800	215
39/116	800	235
60/148	800	265
75/171	850	290
98/171	850	320
98/220	850	355
127/220	850	355
147/220	850	355

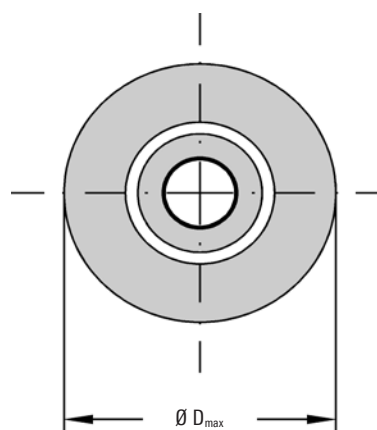

Through connection, PN 25

Types 30/91 to 200/310, welded

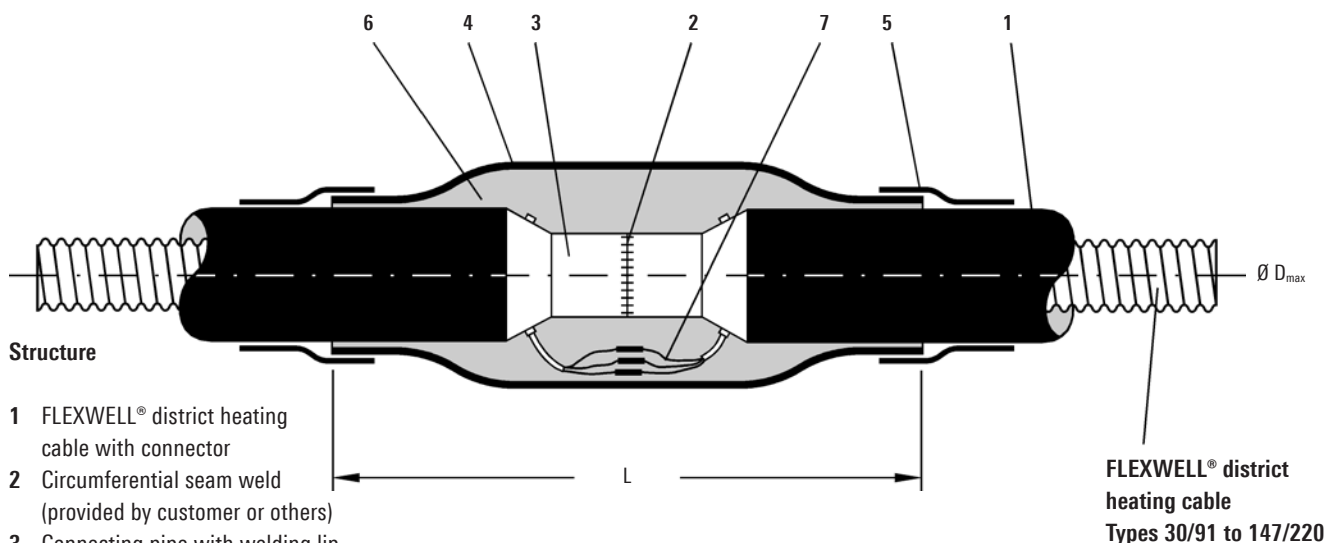

Structure

- 1 FLEXWELL® district heating cable with connector
- 2 Circumferential seam weld (provided by customer or others)
- 3 Connecting pipe with welding lip
- 4 PE-HD shrink sleeve
- 5 Shrink-on collar
- 6 Rigid PUR foam
- 7 Monitoring wires

FLEXWELL® district heating cable
Types 30/91 to 147/220

FLEXWELL® district heating cable
Type FHK 200/310

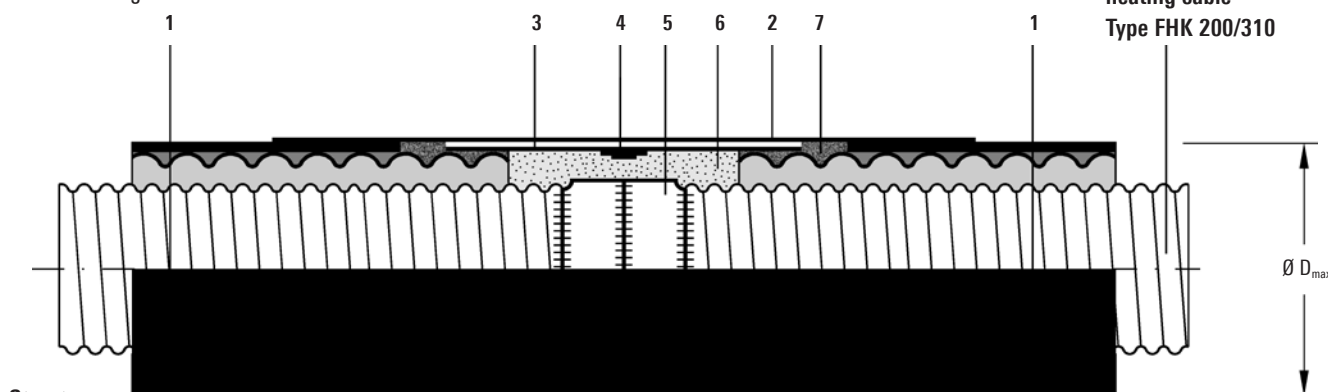

Structure

- 1 FLEXWELL® district heating cable
- 2 Shrink-on collar
- 3 Metal plate collar
- 4 Sealing plug
- 5 Weld ring
- 6 Rigid PUR foam
- 7 Jointing compound

Dimensions of through connection

FHK type	L	Ø D _{max}
	mm	mm
30/ 91	800	215
39/116	800	235
60/148	800	265
75/171	850	290
98/171	850	320
98/220	850	355
127/220	850	355
147/220	850	355
200/310	900	320

Connector, PN 25

Types 30/91 to 75/171, GR version

The FHK connector with the type GR graphite ring seal (Figure 1) is specifically designed for use with FLEXWELL® district heating cable for heating and domestic water pipes, up to a dimension of DN 65. It is used to make all connections on pipe installations in buildings and shafts, and for through-type and T-joints. The monitoring wires pass through a watertight exit on the connector.

This connector can withstand loads of up to nominal pressure stage PN 25¹⁾ at a maximum temperature of 150 °C.

Figure 1 : Connector with graphite ring seal, type GR

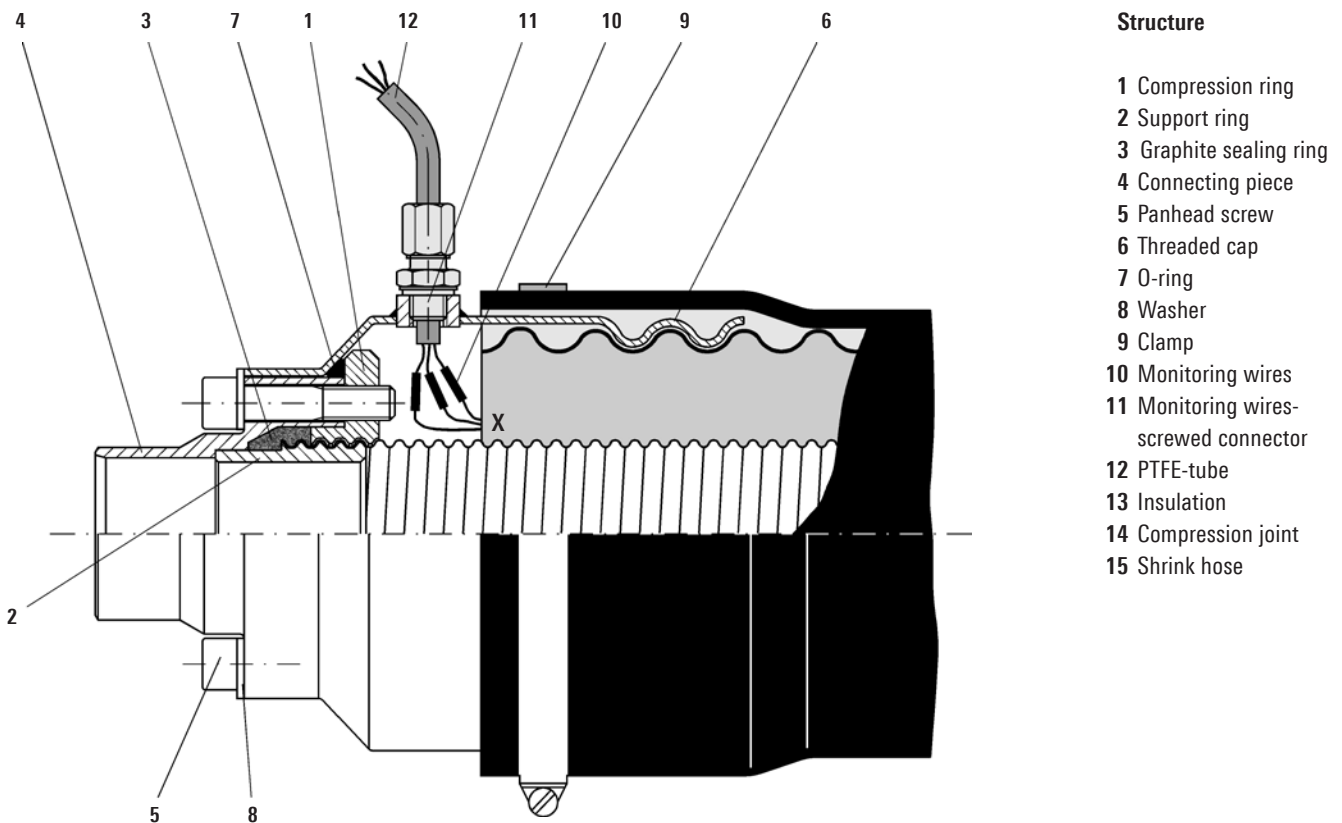

Structure

- 1 Compression ring
- 2 Support ring
- 3 Graphite sealing ring
- 4 Connecting piece
- 5 Panhead screw
- 6 Threaded cap
- 7 O-ring
- 8 Washer
- 9 Clamp
- 10 Monitoring wires
- 11 Monitoring wires-screwed connector
- 12 PTFE-tube
- 13 Insulation
- 14 Compression joint
- 15 Shrink hose

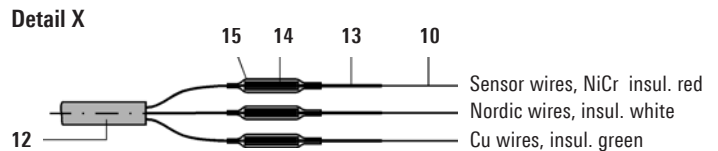
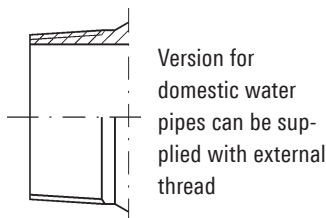

Nominal widths, pipe connection dimensions

FHK type		30/91	39/116	60/148	75/171
Comparable nominal width	[DN]	25	32	50	65
Pipe connection dimensions for hot water pipe	[mm]	33.7 x 2.6	42.4 x 2.6	60.3 x 2.9	76.1 x 2.9
Pipe thread for domestic water pipe		R 1	R 1 1/4	R 2	R 2 1/2

¹⁾Note: For pressure tests in a partially filled trench or with unsupported connectors: max. permitted pressure = 0.5 bar overpressure

Connector, PN 16

Types 98/171 to 147/220, versions A and DE

The FHK connector (Figure 1) is a connecting component specifically designed for FLEXWELL® district heating cables. It is used to make all connections on pipe installations in buildings and shafts and also for through-type and T-joints (FHK 5.305 and FHK 5.300).

Two variants of the connector can be supplied (Figure 2). When delivered, the pipe ends are protected with plastic caps to prevent impurities from entering the inner pipe. Type A connector is intended for hot water pipes. The type DE connector is additionally available in a special version for domestic water pipes. It is supplied with a PTFE-sheathed IT seal. This PTFE sheath must not be removed or damaged.

The monitoring wires pass through a watertight exit on the connector.

These connectors can withstand loads of up to nominal pressure stage PN 16¹⁾ at a maximum temperature of 150 °C.

Figure 1 : Connector (type A)

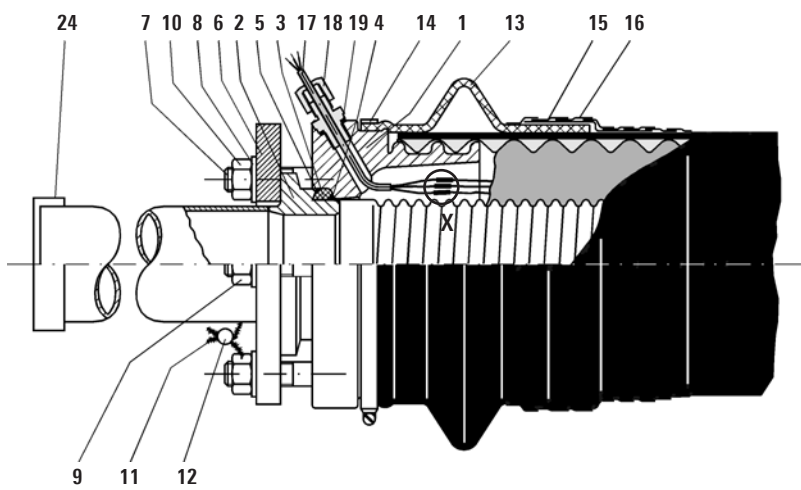

Structure

- 1 Face ring
- 2 Support socket (type A or DE according to choice)
- 3 Lead sealing ring
- 4 Inner wire ring
- 5 Outer wire ring
- 6 Flange ring
- 7 Locking screw
- 8 Washer
- 9 Hexagon nut
- 10 Hexagon nut with transverse bore
- 11 Sealing wire
- 12 Lead seal
- 13 Folded collar
- 14 Strain washer
- 15 Permanently plastic synthetic strip
- 16 PE anti-corrosion strip
- 17 Silicone pipe
- 18 Cable leadthrough, R 1/4"
- 19 Copper sealing ring
- 20 Monitoring wires
- 21 Insulation
- 22 Compression joint
- 23 Shrink hose
- 24 Protective cap

Detail X

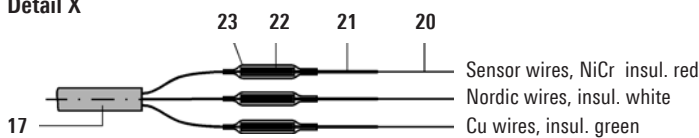

Nominal widths, pipe connection dimensions

FHK type		98/171 98/220	127/220	147/220
Comparable nominal width	DN	80	100	125
Pipe connection dimensions	mm	88.9 x 3.2	114.3 x 3.6	139.7 x 4.0

Figure 2 : Types of execution for the connector

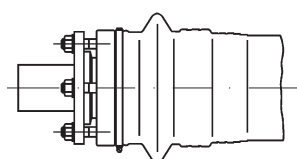

Type A Heating

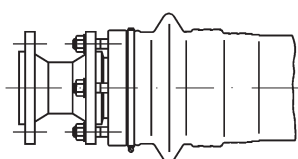

Type DE Sanitary + Heating
Flange connection dimensions after PN 16
Special version available for domestic water pipes.

¹⁾Note: For pressure tests in a partially filled trench or with unsupported connectors: max. permitted pressure = 0.5 bar overpressure

Connector, PN 25

Types 30/91 to 200/310, G versions, welded

FLEXWELL® district heating cable types 30/91 to 147/220

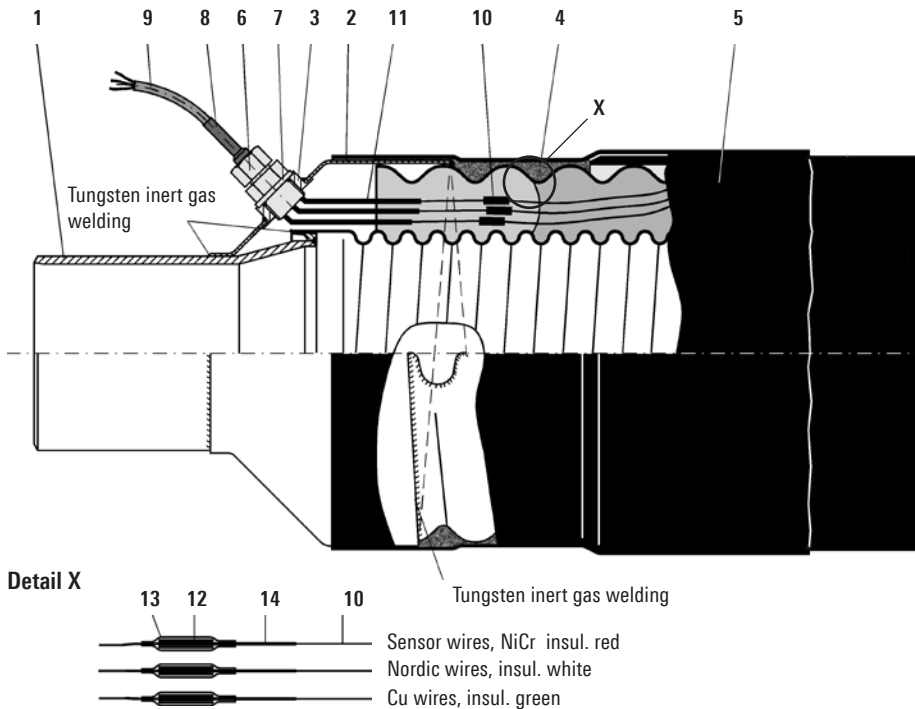

Structure

- 1 Connecting piece with weld-on end
- 2 Protective cap
- 3 Threaded component, R ½"
- 4 Permanently flexible jointing compound
- 5 Shrink hose
- 6 Monitoring wire leadthrough, R ½"
- 7 Sealing ring
- 8 Shrink hose
- 9 PTFE hose line
- 10 Monitoring wires
- 11 Shrink hose
- 12 Compression joint
- 13 Shrink hose
- 14 Insulation

FLEXWELL® district heating cable type FHK 200/310

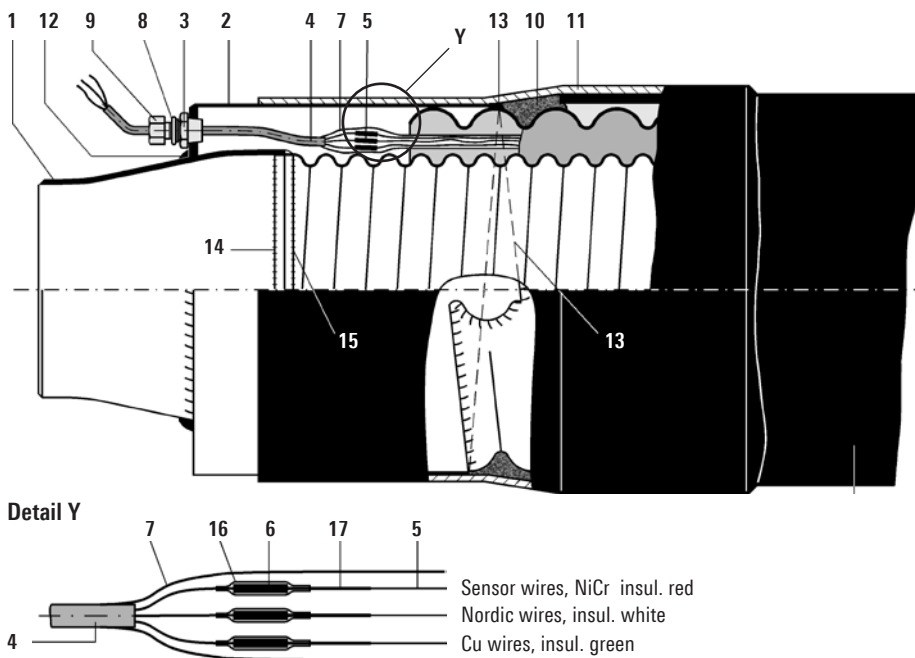

Structure

- 1 Connecting piece with weld-on end
- 2 Protective cap
- 3 Reduction nipple
- 4 PTFE hose line
- 5 Monitoring wires
- 6 Compression joint
- 7 Glass fiber hose
- 8 Sealing ring
- 9 Screwed cable joint
- 10 Permanently flexible jointing compound
- 11 Shrink-on collar
- 12 Weld seam (protective cap/connection piece)
- 13 Weld seam (protective cap/outer corrugated pipe)
- 14 Weld seam ("black" / "white")
- 15 Weld seam ("white" / "white")
- 16 Shrink hose
- 17 Insulation

Nominal widths, pipe connection dimensions

FHK type		30/91	39/116	60/148	75/171	98/171 98/220	127/220	147/220	200/310
Comparable nominal width	DN	25	32	50	65	80	100	125	150
Pipe connection dimensions	mm	33.7 x 2.6	42.4 x 2.6	60.3 x 2.9	76.1 x 2.9	88.9 x 3.2	114.3 x 3.6	139.7 x 4.9	168.3 x 4.5

Note: For pressure tests in a partially filled trench or with unsupported connectors: max. permitted pressure = 0.5 bar overpressure

Wall leadthrough

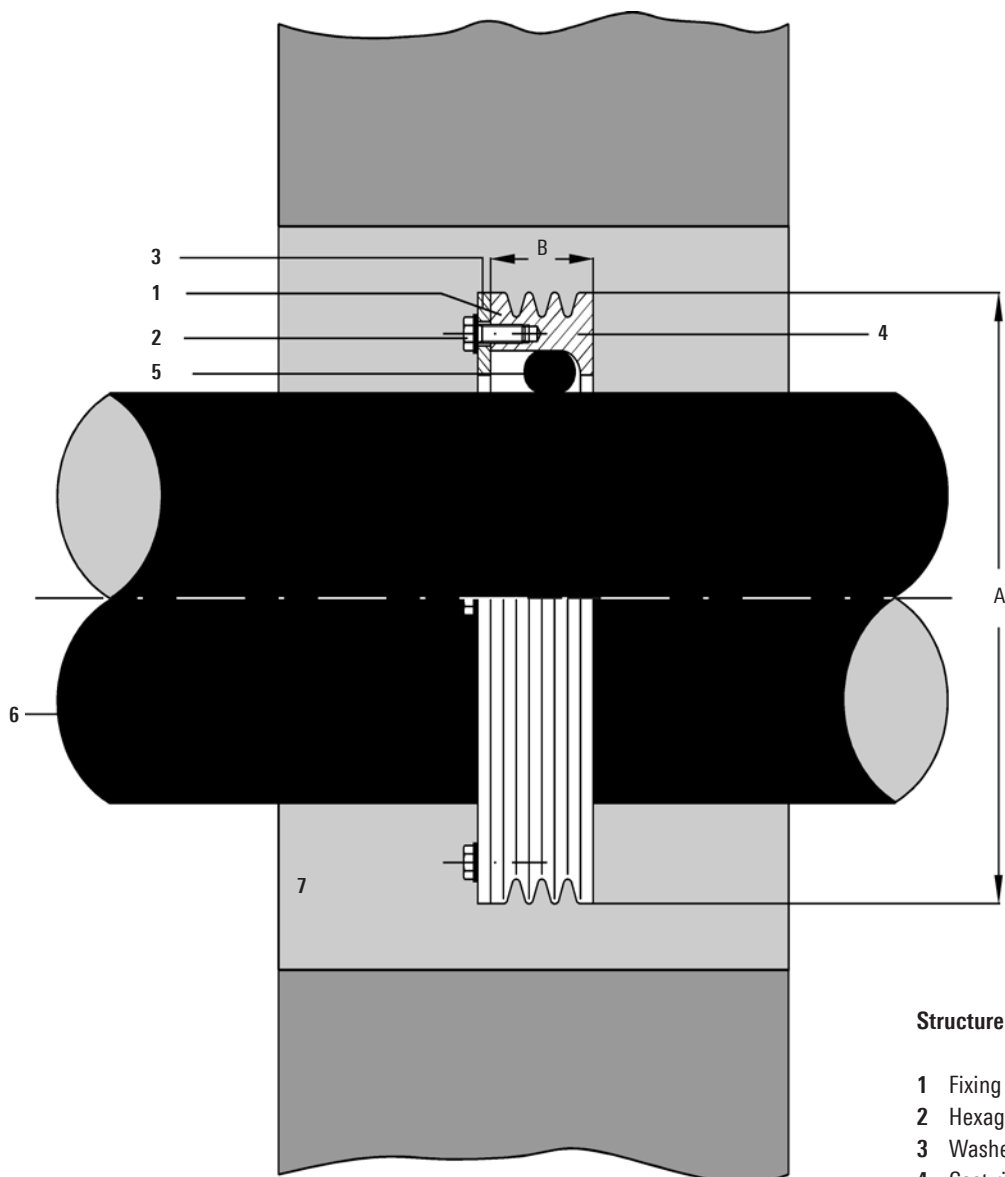

Structure

- 1 Fixing ring
- 2 Hexagon screw, M6 x 20
- 3 Washer
- 4 Cast ring
- 5 Sealing ring
- 6 FLEXWELL® district heating cable
- 7 Concrete

FHK type	A mm	B mm	Sealing rings Piece
30/ 91	160	40	1
39/116	186	40	1
60/148	221	40	1
75/171	243	40	1
98/171	243	40	1
98/220	298	40	1
127/220	298	40	1
147/220	298	40	1
200/310	378	75	2

Wall leadthrough

with core bore or fiber cement liner pipe (impermeable to pressure from water)

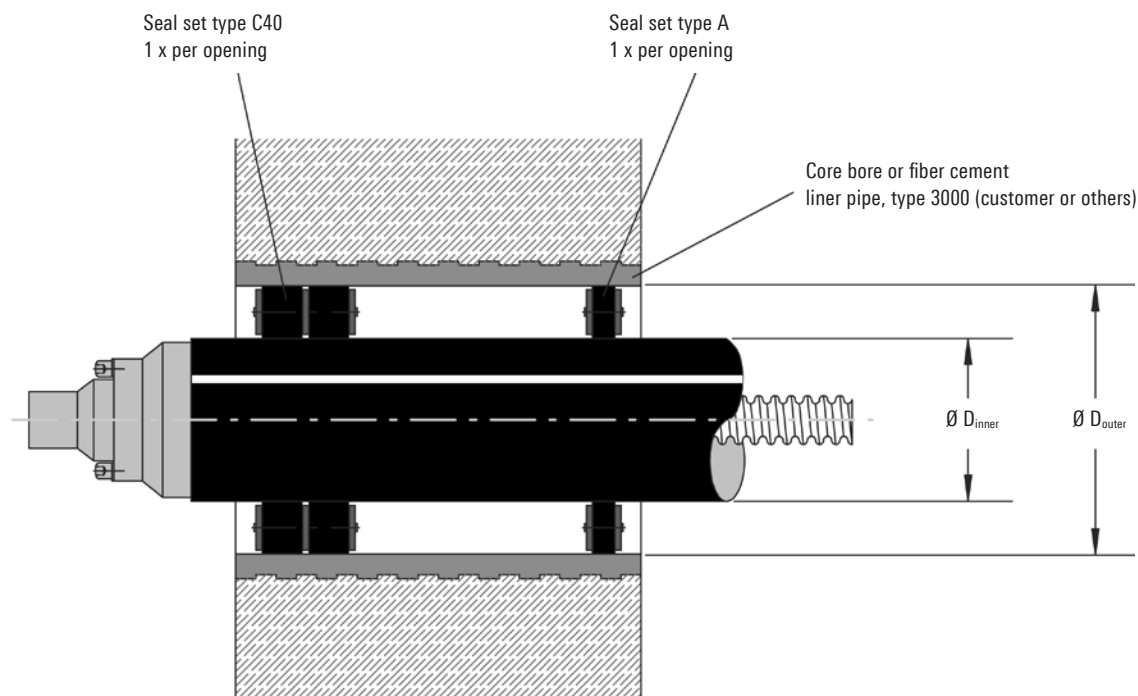

1 x type C40 + 1 x type A must be provided for each pipe leadthrough!

FHK type	DN	Ø core bore or sealing set		
		Liner pipe 3000 mm	Ø D _{inner} mm	Ø D _{outer} mm
30/ 91	25	150	94	150
39/116	32	200	121	200
60/148	50	250	156	250
75/171	65	250	178	250
98/171	80	250	178	250
98/220	80	300	233	300
127/220	100	300	233	300
147/220	125	300	233	300
200/310	150	400	313	400

When ordering the sealing insert, diameters "D_{inner}" and "D_{outer}" must be stated.

Perfect bores are required for installation. As hairline cracks may be present in the concrete or could be caused by processing, it is advisable for customers or others to seal the entire length of the borehole wall with suitable sealant (such as AQUAGARD). Tightness can only be achieved if this recommendation is followed.

After fitting the sealing insert, no further axial movement of the pipe is permitted.

Wall leadthrough

with steel liner pipe (impermeable to pressure from water)

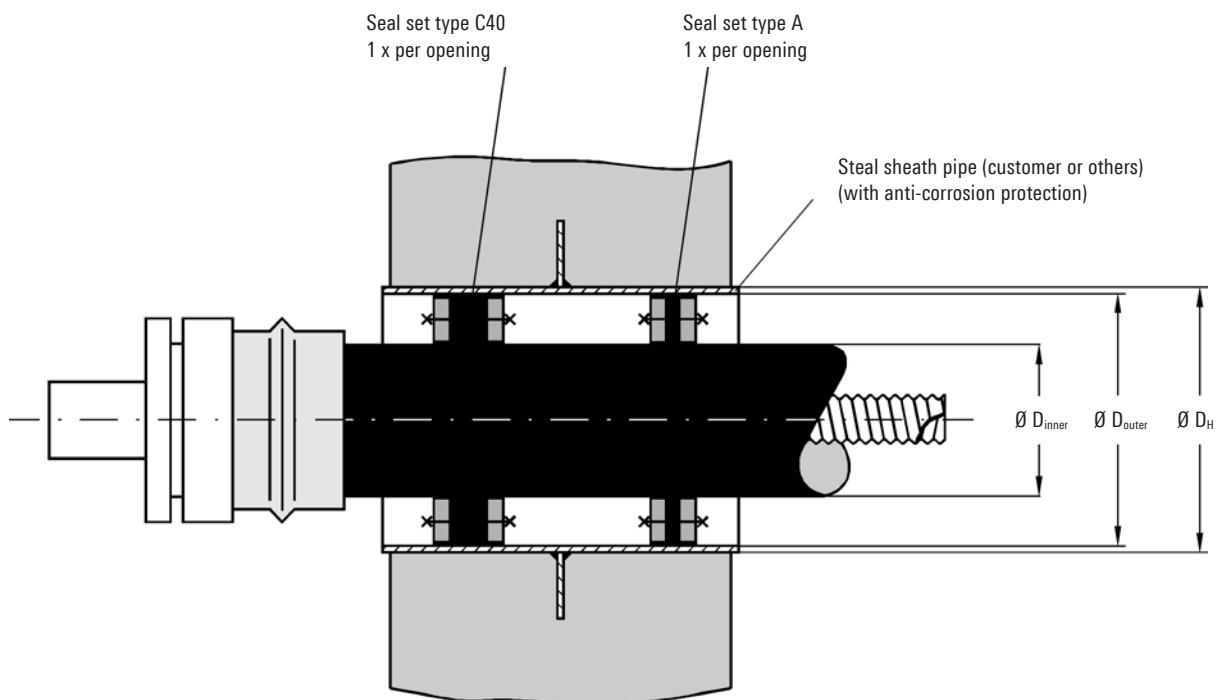

1 x type C40 + 1 x type A must be provided for each pipe leadthrough!

FHK type	DN	Steel sheath pipe	Seal set	
		Ø D _H mm	Ø D _{inner} mm	Ø D _{outer} mm
30/ 91	25	168.3 x 4.5	94	159
39/116	32	219.1 x 6.3	121	206
60/148	50	244.5 x 6.3	156	231
75/171	65	273.0 x 6.3	178	260
98/171	80	273.0 x 6.3	178	260
98/220	80	323.9 x 7.1	233	309
127/220	100	323.9 x 7.1	233	309
147/220	125	323.9 x 7.1	233	309
200/310	150	406.4 x 6.3	313	393

When ordering the sealing insert, the inner diameter of the steel sheath pipe (= Ø D_{outer}) must be stated.

After fitting the sealing insert, no further axial movement of the pipe is permitted.

Sheath pipe entry

impermeable to water pressure

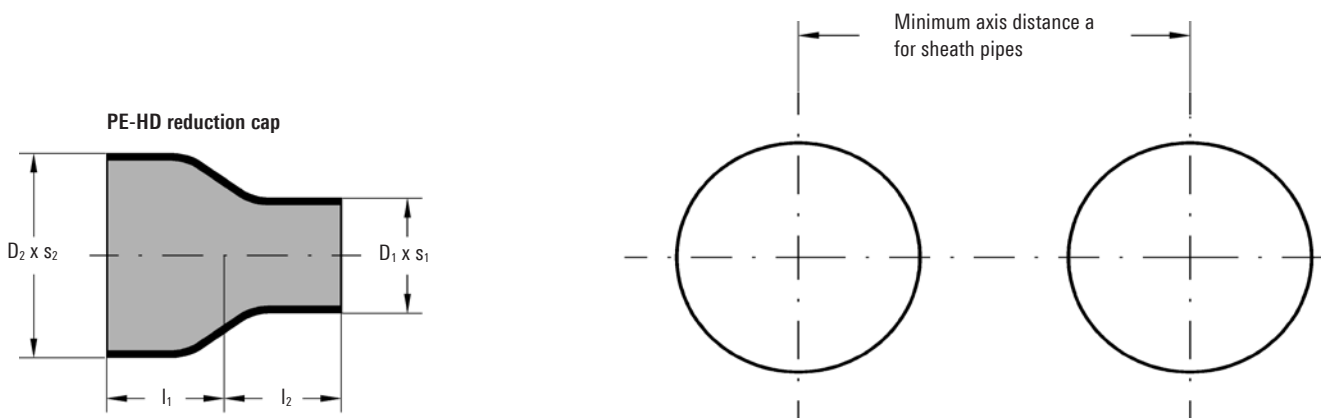
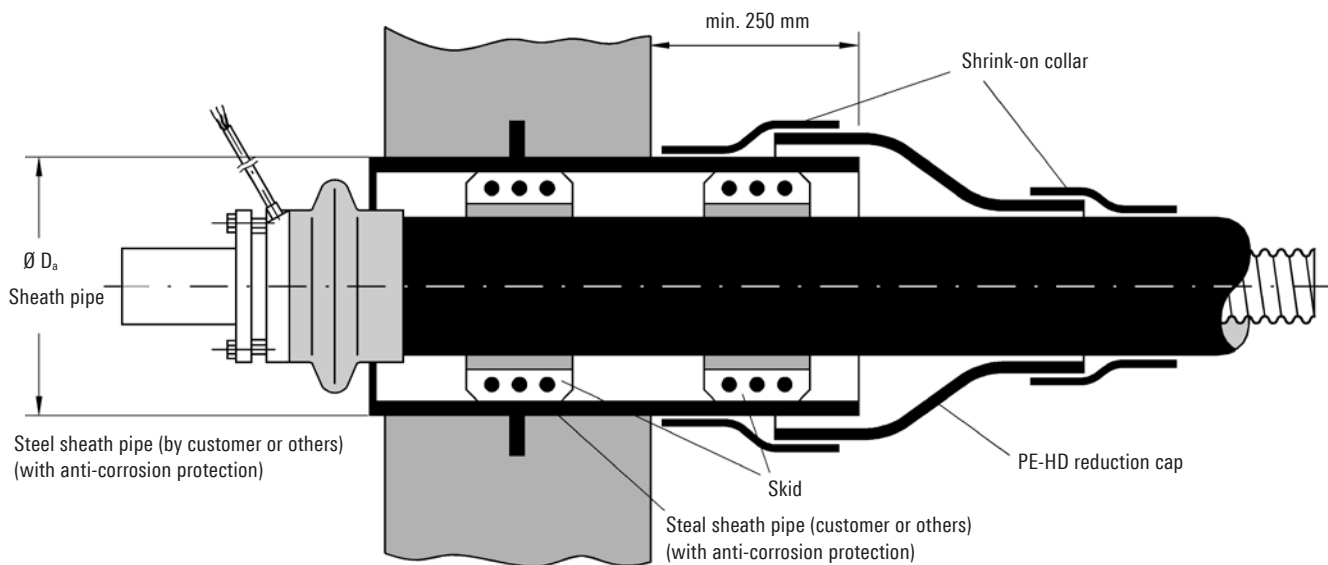

FLEXWELL® district heating cable type		30/91	39/116	60/148	75/171 98/171	98/220 127/220 147/220	200/310
Outer \varnothing of FHK over PE	mm	94	121	156	178	233	310
Steel sheath pipe with Anti-corrosion protection	$\varnothing D_a \times s$ mm	DN 150 (168.3 x 4.5)	DN 150 (168.3 x 4.5)	DN 200 (219.1 x 5.9)	DN 250 (273.0 x 6.3)	DN 300 (323.9 x 7.1)	DN 400 (406.4 x 6.3)
Minimum axis distance a	mm	360	360	410	460	500	560
FP skid type		1 F + 1 G25	2 C 15	2 F + 1 G25	2 M36	2 M + 1 N36	2 M + 2 N36
PE-HD reduction cap	$\varnothing D_1 \times s_1$ mm	110 x 3.0	137 x 2.8	175 x 3.8	196 x 4.0	250 x 4.9	339 x 4.5
	$\varnothing D_2 \times s_2$ mm	196 x 4.0	196 x 4.0	245 x 4.5	303 x 5.5	340 x 6.0	422 x 6.0
	l_1 and l_2 mm	150	150	150	150	150	150
Shrink-on hoop							
Transition, FHK/red. sleeve type	WTD	150 x 450 lg	150 x 530 lg	150 x 650 lg	150 x 720 lg	150 x 890 lg	225 x 1170 lg
Transition, sheath pipe/red. sleeve type	WTD	150 x 720 lg	150 x 720 lg	150 x 870 lg	225 x 1060 lg	225 x 1170 lg	225 x 1430 lg
Connecting strap							
Transition, FHK/red. sleeve type	CLW	145 lg	145 lg	145 lg	145 lg	145 lg	220 lg
Transition, sheath pipe/red. sleeve type	CLW	145 lg	145 lg	145 lg	220 lg	220 lg	220 lg

House entry bend

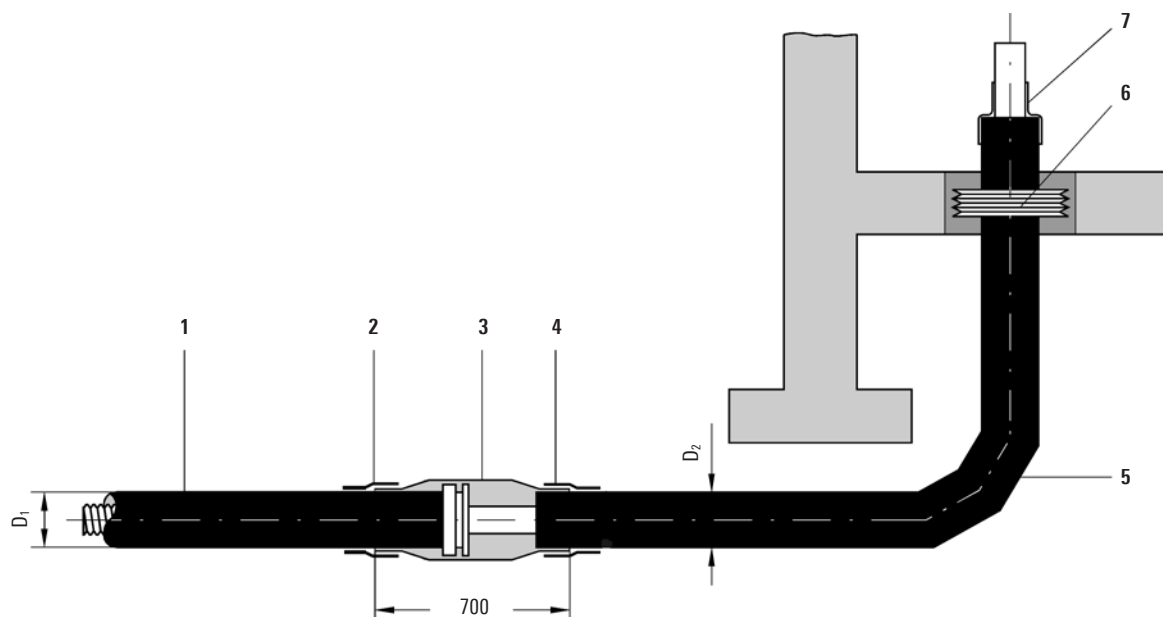

Structure

- 1 FLEXWELL® district heating cable with connector (A, DE or GR)
- 2 Shrink-on collar
- 3 PE-HD shrink sleeve
- 4 Shrink-on collar
- 5 Bend, 90° pre-insulated, 1.5 x 1.5 m, steel or stainless steel
- 6 Labyrinth seal
- 7 End cap

FHK type	DN	FHK outer Ø	
		D ₁	D ₂
30/ 91	25	94	90
39/116	32	121	110
60/148	50	156	125
75/171	65	178	140
98/171	80	178	160
98/220	80	233	200
127/220	100	233	200
147/220	125	233	225
200/310	150	313	250

Figures in mm

Loop-in method

Type of routing/installation

The flexible design of FLEXWELL® district heating cable makes it suitable for installation using the 'loop-in method' which originated in the cable technology business (Figure 2).

The benefits of this are:

- no branches or connection points in the ground
- risks are reduced
- safety and reliability are increased
- costs are cut
- fittings can be installed at low cost inside buildings.

Figure 1 Conventional type of installation, joints and branches in the ground

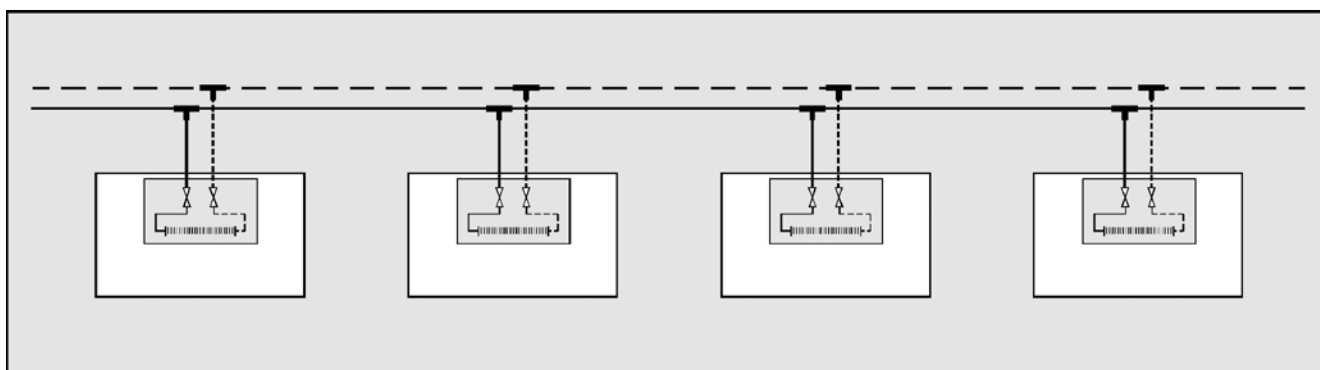
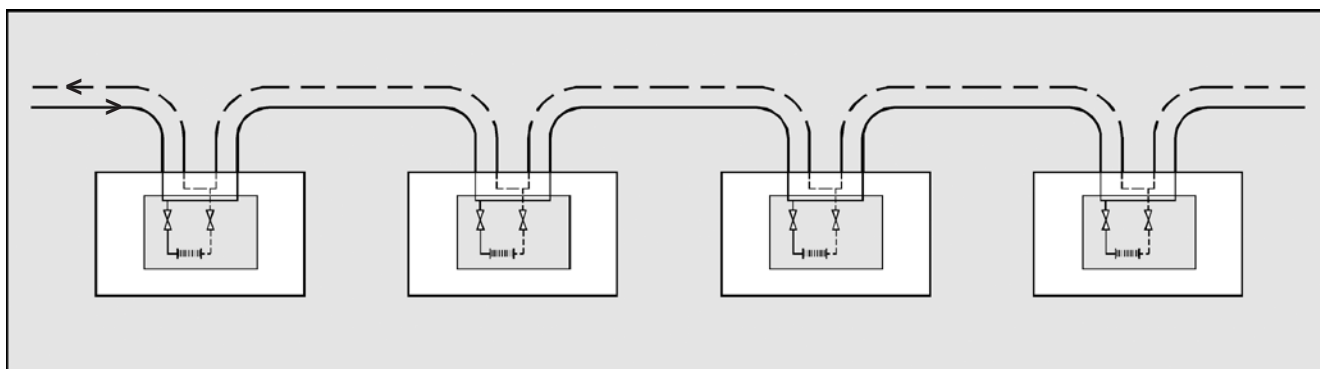
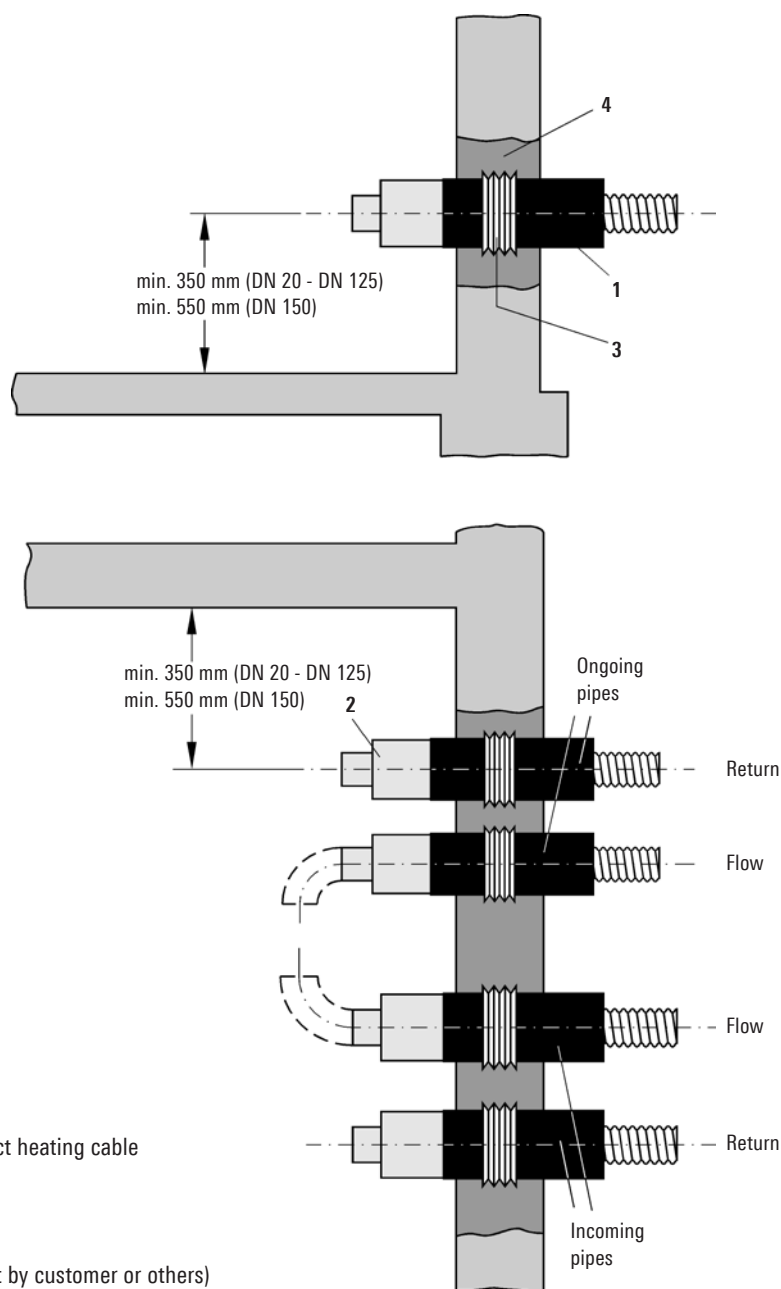

Figure 2 Loop-in method, joints in buildings



Loop-in method

Building entries



Structure

- 1 FLEXWELL® district heating cable
- 2 Connector
- 3 Wall leadthrough
- 4 Wall opening
(sealed watertight by customer or others)

Facilities for drainage or venting must be provided by the customer or others depending on the elevation (high/low points).

For the size and positioning of wall openings, see worksheets FHK 5.555 and FHK 5.560.

Dimensions for axis and wall distances

Connector types 30/91 to 75/171

Connector with graphite ring seal, type GR

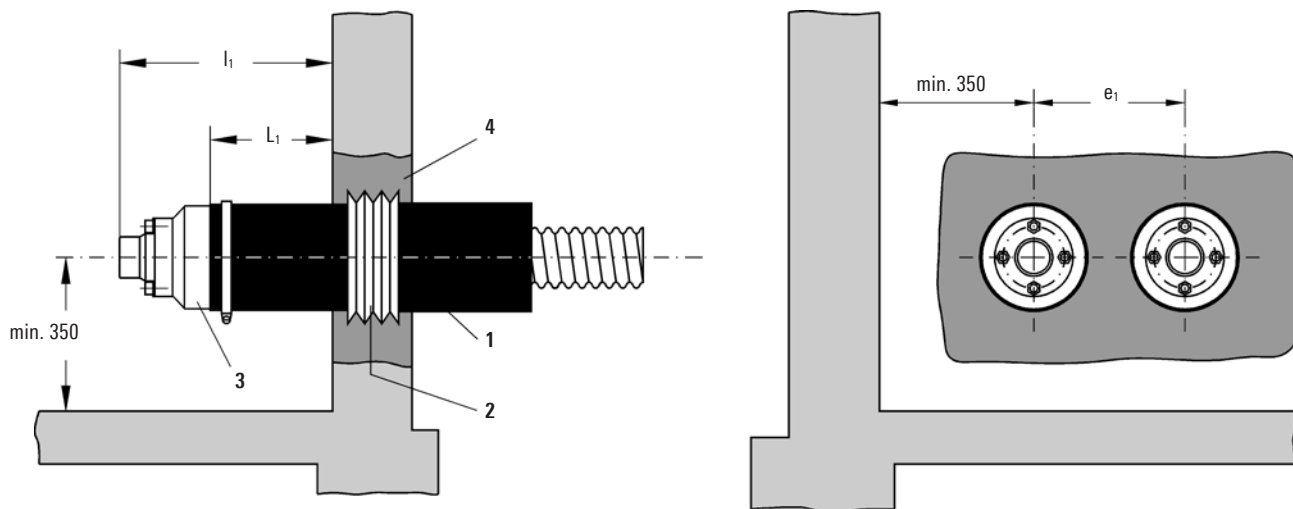

Structure

- 1 FLEXWELL® district heating cable
- 2 Wall leadthrough
- 3 Connector type GR
- 4 Wall opening sealed watertight by customer or others
(For the size and positioning of wall openings, see worksheets FHK 5.555 and FHK 5.560)

Nominal widths, dimensions for pipe connections, wall and axis distances

FHK type	30/91	39/116	60/148	75/171
Comparable nominal width	DN 25	DN 32	DN 50	DN 65
D x s	33.7 x 2.6	42.4 x 2.6	0.3 x 2.9	76.1 x 2.9
e ₁	165	200	240	270
L ₁	120	130	145	145
I ₁	220	240	280	300

Figures in mm

Dimensions for axis and wall distances

Connector types 98/171 to 147/220

Connector (type A)

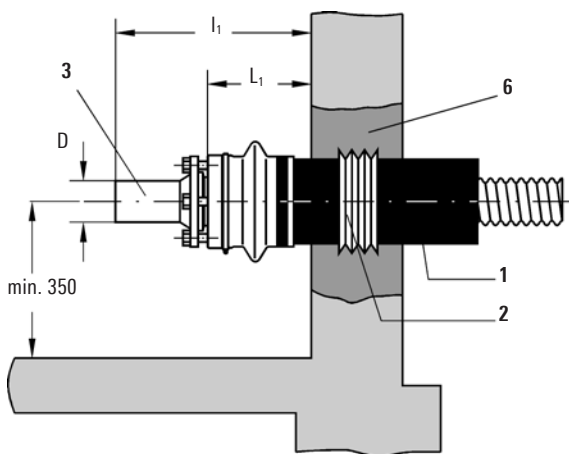

Connector (type DE)

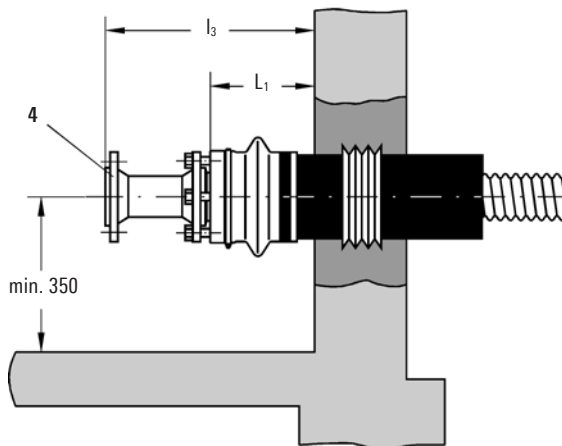

Dimensions for axis and wall distances

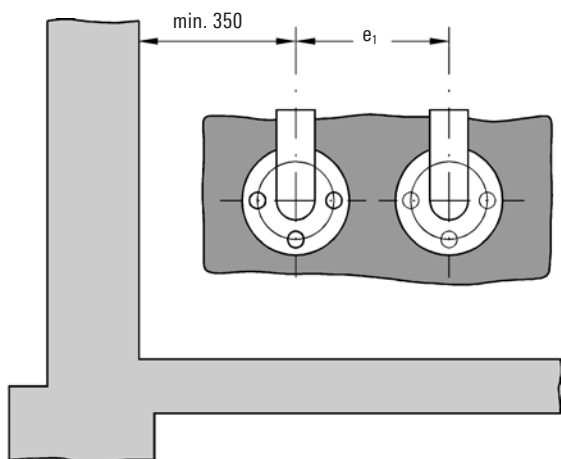

Structure

- 1 FLEXWELL® district heating cable
- 2 Wall leadthrough
- 3 Connector (type A)
- 4 Connector (type DE)
- 5 Wall opening sealed watertight by customer or others
(For the size and positioning of wall openings,
see worksheets FHK 5.555 and FHK 5.560)

Nominal widths, dimensions for pipe connections, wall and axis distances

FHK type	98/171	98/220	127/220	147/220
Comparable nominal width	DN 80	DN 80	DN 100	DN 125
D x s	88.9 x 3.2	88.9 x 3.2	114.3 x 3.6	139.7 x 4.0
e ₁	270	310	310	310
L ₁	235	280	280	280
r	122	122	150	180
l ₁	385	385	430	430
l ₂	385	385	455	490
l ₃	400	400	445	445

Figures in mm

Dimensions for axis and wall distances

Connector, welded, types 30/91 to 200/310

Figure 1: Connector, version G, welded

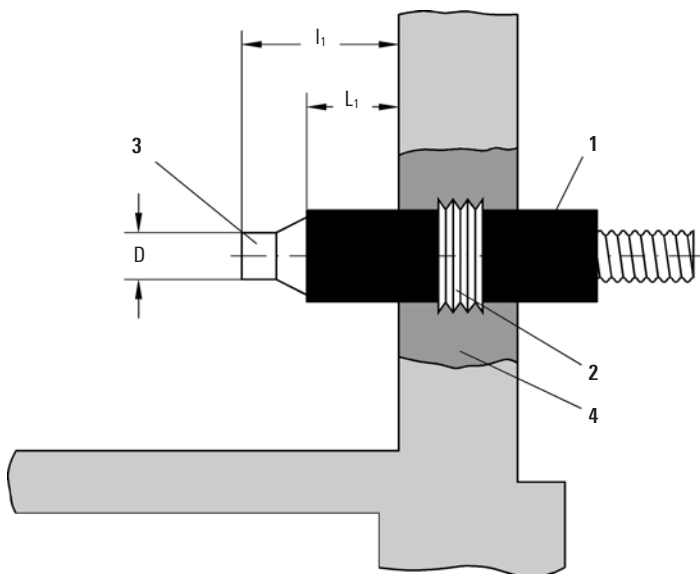

Structure

- 1 FLEXWELL® district heating cable
- 2 Wall leadthrough
- 3 Connector
- 4 Wall opening sealed watertight by customer or others
(For size and position of wall openings, see worksheets FHK 5.555 and FHK 5.560)

Figure 2: Wall and axis distances

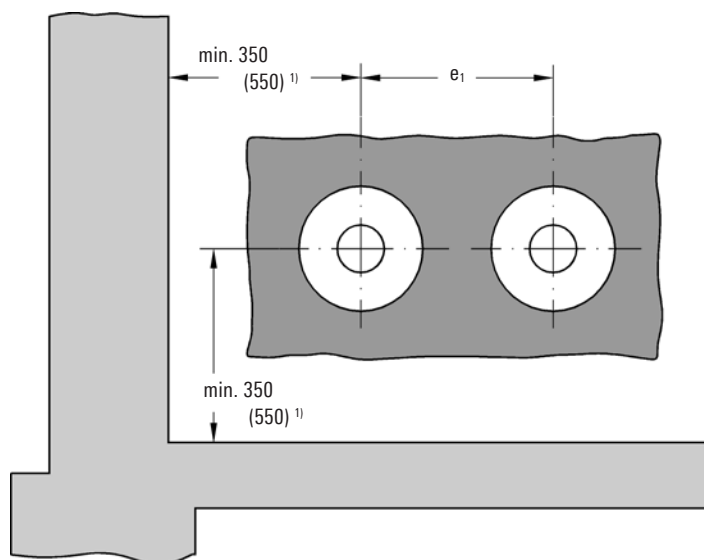

Nominal widths, dimensions for pipe connections, wall and axis distances

FHK type	30/91	39/116	60/148	75/171	98/171	98/220	127/220	147/220	200/310
Comparable nominal width	DN 25	DN 32	DN 50	DN 65	DN 80	DN 80	DN 100	DN 125	DN 150
D x s	33.7 x 2.6	42.4 x 2.6	60.3 x 2.9	76.1 x 2.9	88.9 x 3.2	88.9 x 3.2	114.3 x 3.6	139.7 x 4.0	168.3 x 4.5
e_1	165	200	240	270	270	310	310	310	410
L_1	215	215	230	235	235	280	280	280	210 (310) ¹⁾
l_1	377	373	383	388	385	385	426	426	300 (400) ¹⁾

¹⁾ Dimensions in parenthesis are valid for installing connectors on site. Dimensions without parentheses are valid for pipes fabricated in the factory.
Figures in mm

Installation through protective pipes

The following points should be noted when installing FLEXWELL® district heating cable (FHK) through protective pipes:

1. In order to ensure that the FHK is guided perfectly as it is drawn in. One protective pipe is required for each FHK. The protective pipe must be laid straight, with no angles. Protective pipes must not have any offsets on their joints which could impede or prevent the drawing-in procedure, or which could cause damage to the outer PE protective casing.
2. When the throughpress process is used, it is not always possible to introduce two small protective pipes into the ground next to one another; in these cases, one large protective pipe is pressed in instead. It is essential to contact us beforehand in order to agree on a structural solution.
3. Sufficient working space must be available at ground level in front of and behind the protective pipe to enable the traction engine to shunt easily with the cable trailer, so it can draw the FHK into the protective pipe without any angular deviations from the pipeline axis.
4. Bends in the pipe routing must be avoided directly upstream or downstream of the protective pipes. If this cannot be ensured, the pipe routing must be agreed with us beforehand.
5. For protective pipes made of PVC, PE or fiber cement, the FHK is drawn in without skids. For steel and concrete protective pipes skids should be used. The inner diameter of the protective pipes should be at least 20 mm larger than the outer diameter of the FHK or the skids (FHK 5.530, Figures 1 and 2).

Installation through protective pipes

Figure 1: Installing FHK through straight-running protective pipes without offset, not using skids.
 Max. length of protective pipe ≥ 50 m¹⁾

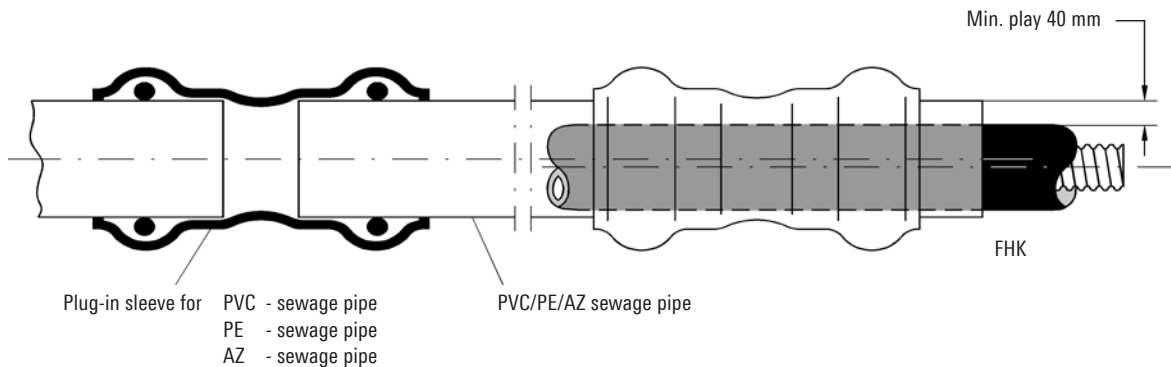
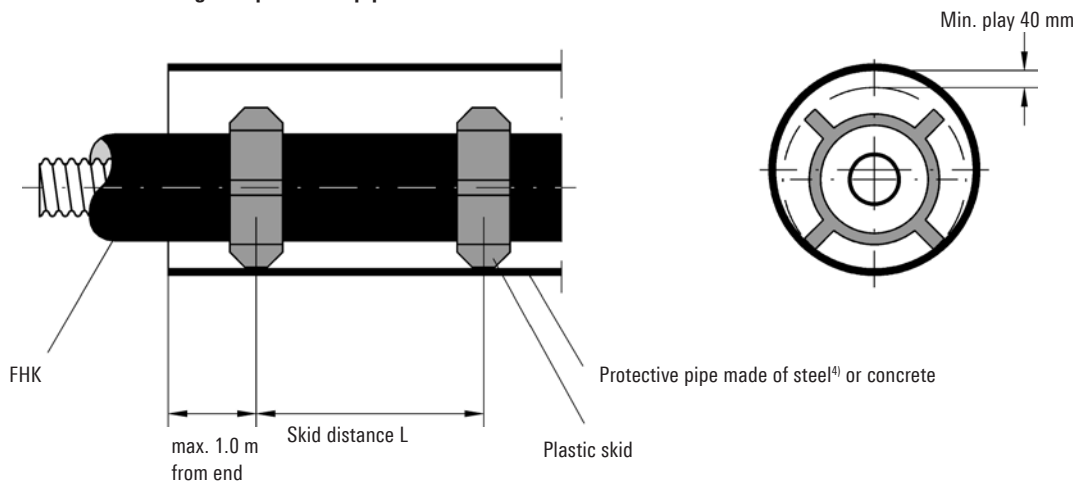

Figure 2: Installing FHK through straight-running protective pipes without offset, using skids.
 Max. length of protective pipe ≥ 50 m¹⁾



FLEXWELL® district heating cable type		30/91	39/116	60/148	75/171 98/171	98/220 127/220 147/220	200/310
FHK casing pipe Ø max.	mm	95	121	156	178	233	313
Skid distance L	m	2.00	2.00	2.50	3.00	3.00	4.00
without skids							
PVC sewage pipe to DIN 19 534 ²⁾	mm	125 x 3	160 x 3.6	200 x 4.5	250 x 6.1	315 x 7.7	400 x 9.8
Play between FHK and PVC pipe	mm	24	32	35	60	67	67
AZ sewage pipe to DIN 19 850 ²⁾	mm	141 x 8	168 x 9	220 x 10	274 x 12	328 x 14	436 x 18
Inner pipe Ø	mm	125	150	200	250	300	400
Play between FHK and AZ pipe	mm	30	29	44	72	67	87
with skids							
Steel pipe to DIN 2458 ³⁾⁴⁾	mm	168.3 x 4	219.1 x 4.5	219.1 x 4.5	273 x 5	323.9 x 5.6	406.4 x 6.3
Inner pipe Ø	mm	160	210	210	263	313	394
Skid (company: Frankenplastik)		3 S19	4 S19	4 T19	2 F + 1 G25	3 F + 1 G25	4 F + 1 G25
Play between FHK and pipe	mm	27	51	20	35	30	31

1) after consulting BRUGG Pipe Systems

2) Min. coverage height for SLW 60 = 0.80 m; for SLW 30 or below a road surface: 0.60 m

3) Min. coverage = 0.60 m

4) Joints without root seam

Horizontal directional drilling (HDD) method

Because of its flexibility and its corrosion-proof outer casing, FLEXWELL® district heating cable is particularly suitable for the horizontal directional drilling (HDD) method described below. This application is possible for the entire series of dimensions from FHK 30/91 to FHK 200/310.

The horizontal directional drilling (HDD) method was developed to install supply pipes and lines without trenches. The horizontal directional drilling method is used wherever protection is required for valuable surface areas (such as parks, protected countryside zones, pedestrian zones, pavements and cobbled paths, gardens in front of buildings, etc.) or where difficult crossings have to be constructed (waterways, canals, roads with heavy traffic, rail lines, embankments or built structures, etc).

Brief technical process description

The boring tool consists of individual hollow drill assemblies which are screwed together, and a drill head equipped with jets.

A water-bentonite mixture atomized under high pressure, in small quantities, cuts and loosens the adjacent ground whilst stabilizing and lubricating the bore hole.

The special shape of the drill head allows targeted changes of direction and precise control of the bore.

At the end of the pilot bore, the drill head is exchanged for a widening head fitted with jets, and the FLEXWELL® district heating cable that is to be drawn in is connected.

At the same time as the drilling assembly is withdrawn, the FLEXWELL® district heating cable is drawn into the bore hole which has been widened and supported by the water-bentonite suspension.

Benefits of the system

- No pipe trenches, earthworks only required for installation pits
- Minimal damage to surfaces
- No consequential damage, e.g. due to subsidence of the ground or road surface
- Disruptions and hazards to stationary and moving traffic are minimal
- Consideration is given to protecting trees and plants
- Process is largely independent of weather conditions
- High-speed working

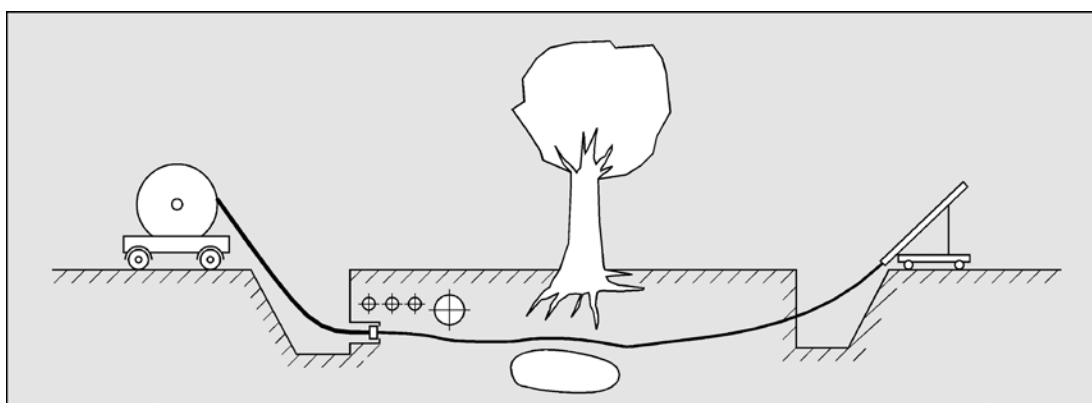

Installation without trenches

Pulling head

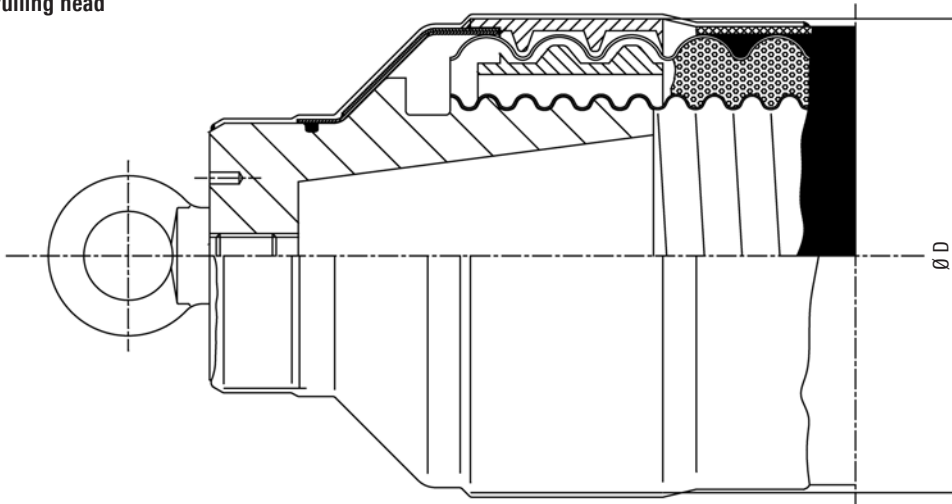

FHK type	D _{max} mm	F _Z KN	Recommended min. bore hole radius m	Recommended min. bore hole diameter mm	Normal bore length m
30/ 91	100	12	25	150	121
39/116	125	15	30	185	112
60/148	160	20	35	240	110
75/171	180	30	50	270	141
98/171	180	40	50	270	190
98/220	230	50	100	345	167
127/220	230	50	100	345	167
147/200	230	60	100	345	201
200/310	320	100	150	480	224

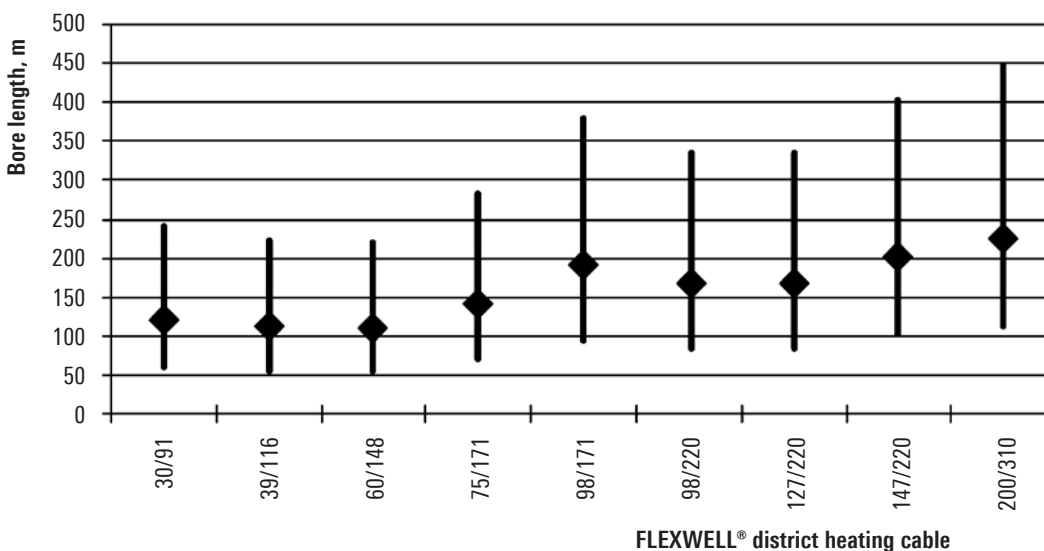

The "normal bore length = ♦" is taken as the standard value and is attainable where ground and installation conditions present no particular difficulties; the project-specific "maximum bore length" must be determined on a case-by-case basis, taking account of local conditions and permissible tensile/tractive forces.

F_Z = permissible tensile/tractive force for the HDD process

A special pulling head must be used for this purpose. The bore hole should be widened to the recommended minimum bore hole diameter before the FLEXWELL® district heating cable is drawn in.

Information for underground construction

Technical regulations, standards, information on execution

Technical regulations, standards

The following standards, regulations and guidelines should be observed as a minimum when carrying out underground construction work for FLEXWELL® district heating cable:

DIN 1072 Road and path bridges, load assumptions
DIN 4033 Drainage ducts and conduits made of prefabricated pipes, guidelines on execution
DIN 4124 Construction pits and trenches, embankments, working space widths, timbering
DIN 18300 VOB, Part C, General technical regulations; earthworks
DIN 18303 VOB, Part C, General technical regulations; cladding work in construction pits
DIN 18304 VOB, Part C, General technical regulations; piling work
DIN 18305 VOB, Part C, General technical regulations; dewatering work
DIN 18307 VOB, Part C, General technical regulations; gas and water pipework in the ground
DIN 18308 VOB, Part C, General technical regulations; drainage work
DIN 18320 VOB, Part C, General technical regulations; landscaping work
DIN 18330 VOB, Part C, General technical regulations; brickwork
DIN 18337 VOB, Part C, General technical regulations; sealing against water not exerting pressure
DIN 18354 VOB, Part C, General technical regulations; asphaltting work
Code of practice: "Securing pipe trenches and construction pits"¹
Information sheet on infilling pipe trenches²
Accident prevention regulations

The trench widths 'B' indicated in the table on worksheet FHK 5.550 are recommended values. However, they do not release those engaged in underground construction work from the duty of diligence in respect of accident prevention regulations or of the aforementioned standards and regulations.

Information on execution

The minimum distances from external supply lines stated in worksheet FHK 5.585 must be respected.
Underground construction data for through connections: see worksheet FHK 5.565; for T-pieces, FHK 5.570.

¹ Employers' Liability Insurance Association of the Construction Industry

² Research Society for Roadbuilding, Underground Working Group, Maastrichter Str. 45, 50672 Cologne

Information for underground construction

Trench dimensions

Figure 1: Layout plan of trench

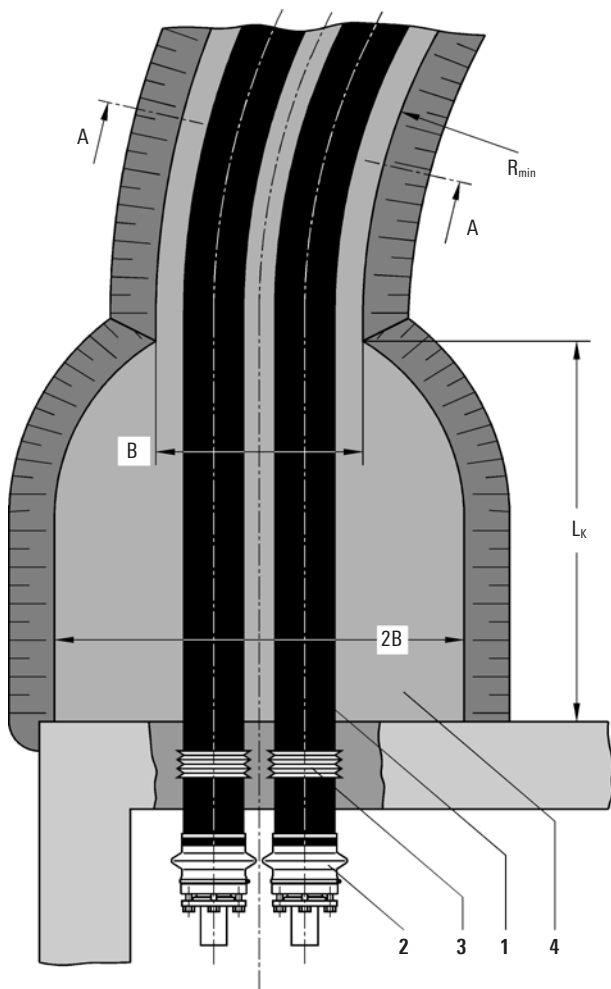
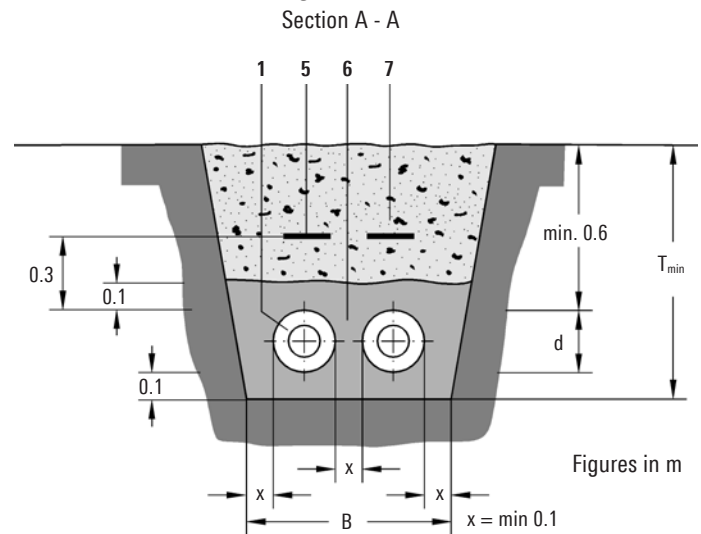

Figure 2: Cross-section of trench



Figures in m

Structure

- 1 FLEXWELL® district heating cable (FHK)
- 2 Connector
- 3 Sealing bushing (wall leadthrough)
- 4 Working space in front of buildings and shafts
- 5 Pipe warning tape (supplied by BRUGG Pipe Systems, installed by customer or others)
- 6 Sand filling (0 - 4 mm round particles)
- 7 Filling material (reusable excavated material)

Trench and working space dimensions, quantities of excavated material and sand filling

FLEXWELL® district heating cable type			30/91	39/116	60/148	75/171 98/171	98/220 127/220 147/220	200/310
Outer diameter of FHK	d	mm	94	121	156	178	233	313
Trench depth T_{min}	for SLW 60 ¹⁾	m	0.80	0.85	0.85	0.90	0.95	1.05
Minimum coverage height t	for SLW 60	m	0.60	0.60	0.60	0.60	0.60	0.60
Trench width B		m	0.50	0.55	0.60	0.65	0.75	0.95
Working space width 2B		m	1.00	1.10	1.20	1.30	1.50	2.00
Working space length L_k		m	0.50	0.50	1.00	1.00	1.50	2.50
Minimum trench radius ²⁾ R_{min}		m	1.00	1.20	1.50	2.00	4.00	5.00
Material excavated from trench ³⁾	for SLW 60	m ³ /m	0.40	0.47	0.51	0.59	0.72	1.00
Sand filling		m ³ /m	0.14	0.16	0.18	0.20	0.24	0.39

Trench widths "B" are recommended values. Please follow generally valid technical rules, guidelines and accident prevention regulations.

- 1) SLW 60 = 100 kN wheel load to DIN 1072
- 2) Smaller radii only after consulting BRUGG Pipe Systems
- 3) Excavation quantities ignoring gradient of embankment

Information for underground construction

Wall openings

Figure 3 : Wall opening for FLEXWELL® connector

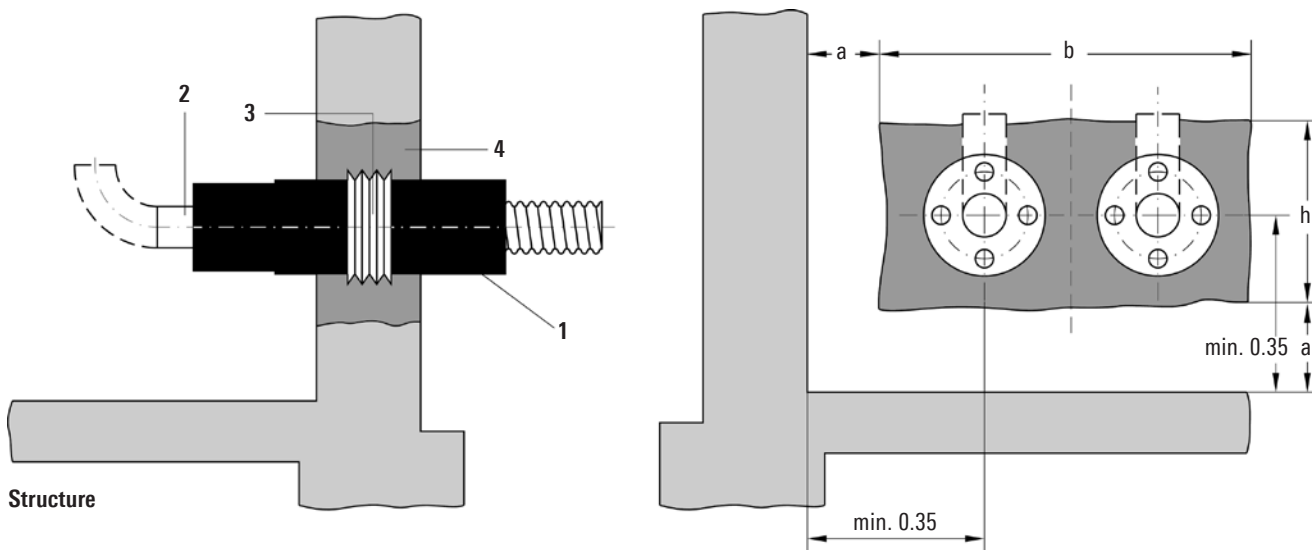

Structure

- 1 FLEXWELL® district heating cable (FHK)
- 2 Connector
- 3 Wall leadthrough
- 4 Concrete (wall opening to be sealed watertight by customer or others)

Figure 4 : Wall opening for loop-in method

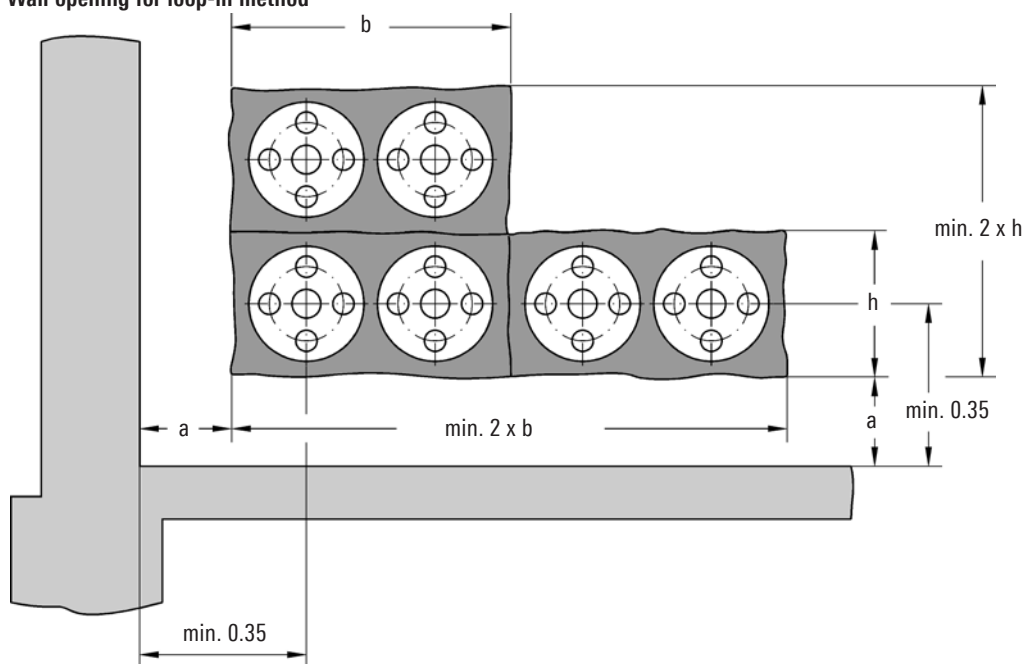

With the loop-in method, wall openings must be widened according to the pipe routing and the dimensions stated below (building statics may need to be checked by customer or others).

Figures in m

Dimensions for wall opening, wall distances

FHK	30/91	39/116	60/148	75/171 98/171	98/220 127/220 147/220	200/310
a	0.26	0.24	0.22	0.21	0.18	0.10
b	0.35	0.45	0.50	0.55	0.65	0.85
h	0.20	0.25	0.30	0.35	0.40	0.50

Information for underground construction

Core bores

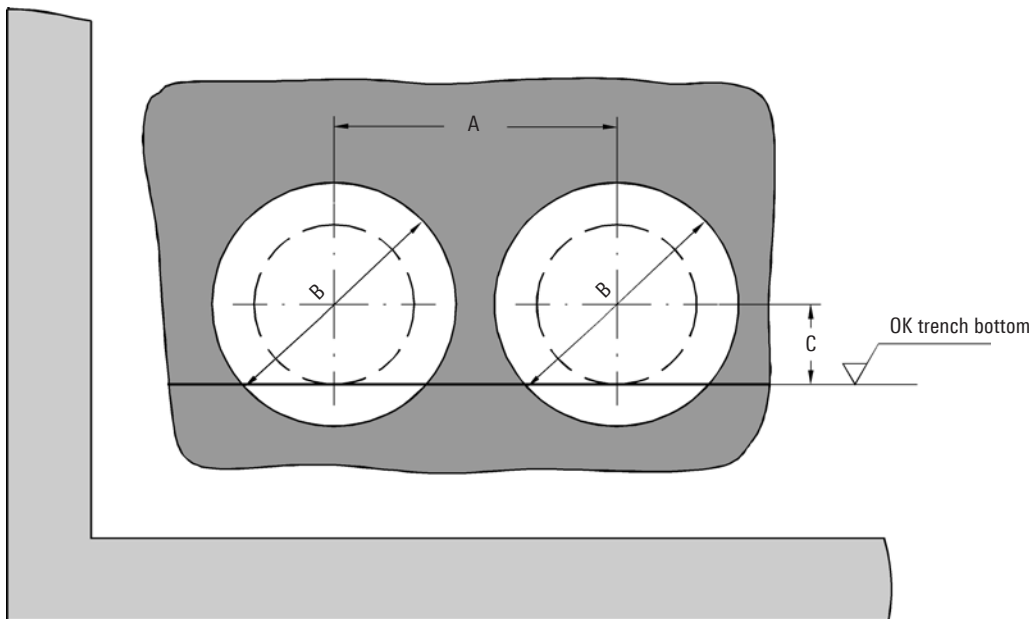

Core bores for Doyma seals, see worksheet 5.335

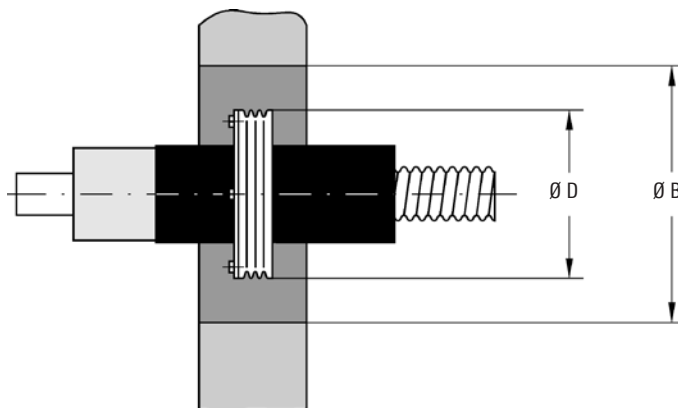

Reference dimensions for core bores

- A Axial distance
- B Core bore diameter
- C Distance: trench bottom-pipe axis
- D Diameter of wall leadthrough

Core bore dimensions*

FHK type	A	B	C	D
30/ 91	260	250	50	160
39/116	310	300	60	185
60/148	310	300	80	221
75/171	360	350	90	243
98/171	360	350	90	243
127/220	410	400	120	298
147/220	410	400	120	298
200/310	410	400	120	298
200/310	460	450	155	378

* only valid for standard wall leadthrough

Figures in mm

Information for underground construction

Through connection

Figure 1: Working space for through connection (side view)

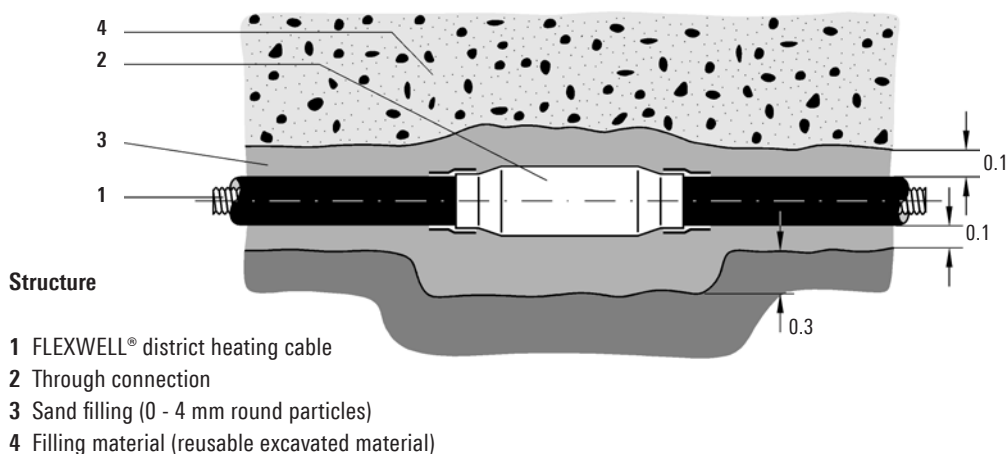
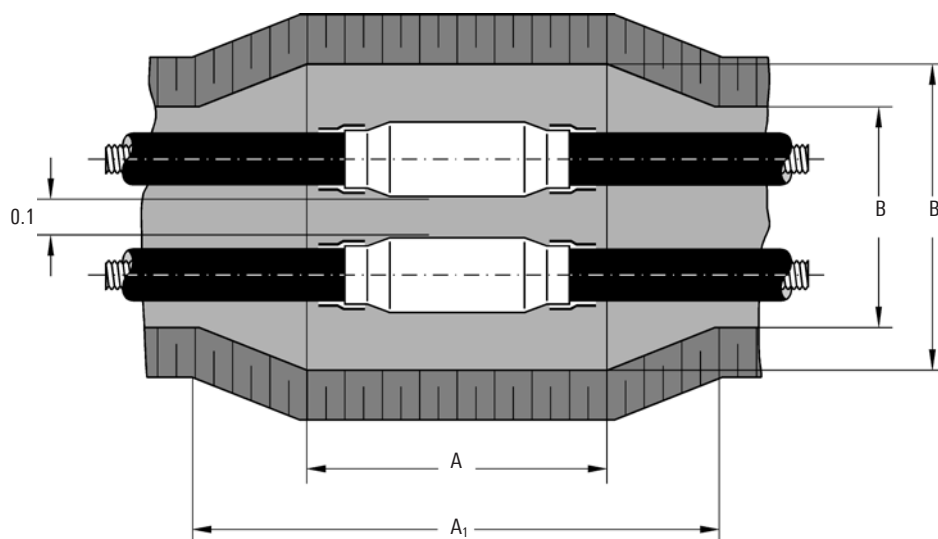

Figure 2: Working space for through connection (top view)



Trench dimensions

FHK type	A	A1	B	B1
30/ 91	1.5	2.5	0.5	1.5
39/116	1.5	2.5	0.55	1.55
60/148	1.5	2.5	0.6	1.6
75/171	2.0	2.5	0.65	1.65
98/171	2.0	4.0	0.65	1.65
98/220	2.0	4.0	0.75	1.75
127/220	2.0	4.0	0.75	1.75
147/220	2.0	4.0	0.75	1.75
200/310	2.0	5.0	1.00	2.00

In case of repair, dimension A1 must be increased by 2.5 m to allow for the radius of the FLEXWELL® district heating cable.

Figures in m

Information for underground construction

T-joint, downward branch

Figure 1 : Connection, working space (top view)
 Dimensions indicated are valid for all FHK types

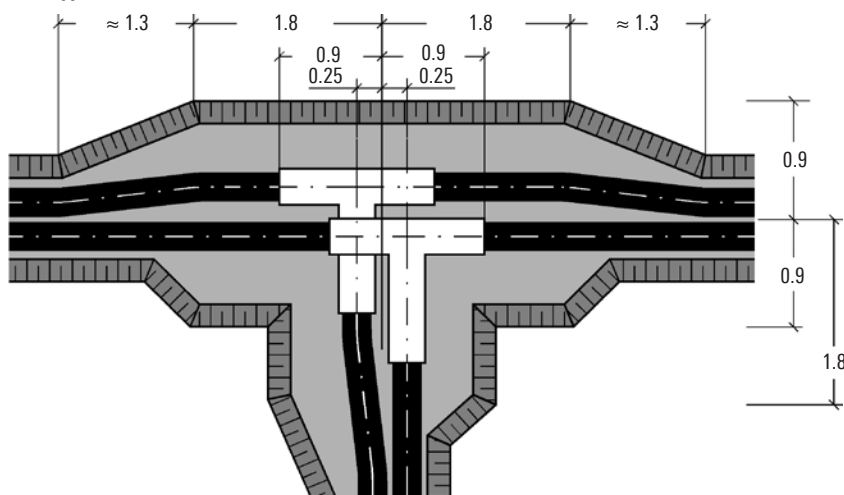
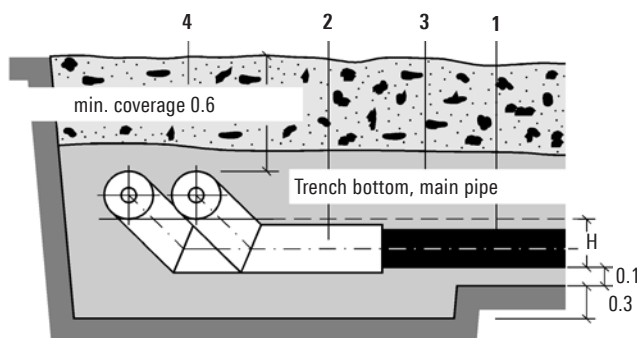

Figure 2 : T-joint, working space
 Downward branch (cross-section)

Structure

- 1 FLEXWELL® district heating cable
- 2 T-joint
- 3 Sand filling (0 - 4 mm round particles)
- 4 Filling material (reusable excavated material)



Trench dimensions, downward branch (Figure 2)

FHK Main pipe	FHK branch pipe								
	30/91	39/116	60/148	75/171	98/171	98/220	127/220	147/220	200/310
30/ 91	0.23								
39/116	0.23	0.25							
60/148	0.23	0.25	0.28						
75/171	0.23	0.25	0.28	0.30					
98/171	0.23	0.25	0.28	0.30	0.32				
98/220	0.23	0.25	0.28	0.30	0.32	0.34			
127/220	0.23	0.25	0.28	0.30	0.32	0.34	0.36		
147/220	0.23	0.25	0.28	0.30	0.32	0.34	0.36	0.36	
200/310	0.19	0.21	0.24	0.26	0.28	0.30	0.32	0.32	0.36

H = dimension of height difference between trench bottom/main pipe and trench bottom/branch pipe

Figures in m

Information for underground construction

House entry bend

Figure 1: House entry bend
Cross-section

Structure

- 1 FLEXWELL® district heating cable
- 2 HD-PE shrink sleeve
- 3 House entry bend, 1.5 x 1.5 m, 90°
- 4 Shrink-on collar
- 5 Labyrinth seal
- 6 End cap
- 7 Sand filling (0 - 4 mm round particles)
- 8 Filling material (reusable excavated material)
- 9 Pipe fixture

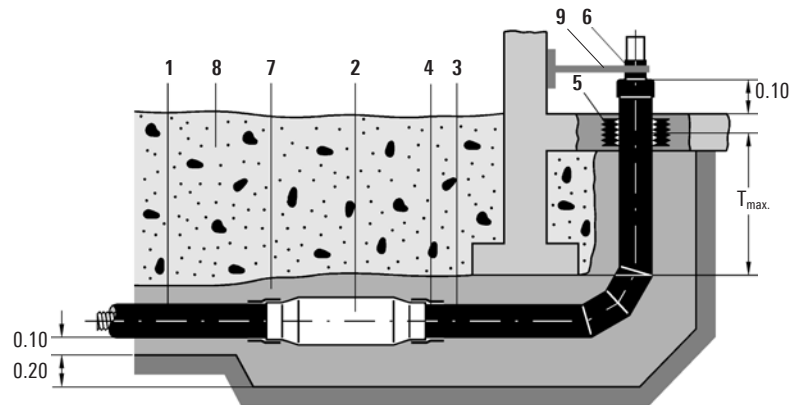
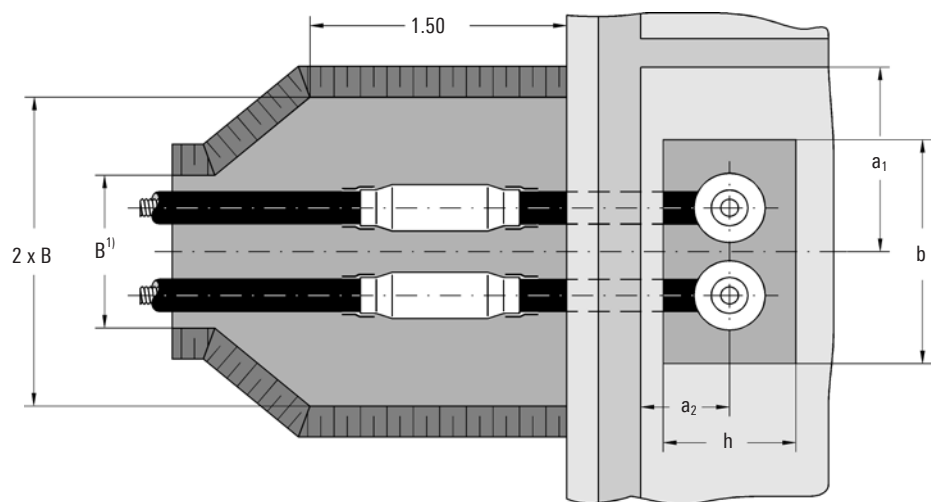

Figure 2: House entry bend
Top view



FHK type	Minimum dimensions						T max. Distance to lower edge Foundation
	B Trench width	a lateral wall distance to middle opening	a ₂ ²⁾ wall distance to middle opening	b Length of opening	h Width of opening		
30/ 91	0.50	0.30	0.15	0.49	0.20	1.00	
39/116	0.55	0.32	0.16	0.53	0.25	1.00	
60/148	0.60	0.34	0.16	0.57	0.30	0.98	
75/171	0.65	0.36	0.17	0.62	0.35	0.98	
98/171	0.65	0.38	0.18	0.66	0.35	0.97	
98/220	0.75	0.41	0.20	0.72	0.40	0.96	
127/220	0.75	0.42	0.20	0.74	0.40	0.95	
147/220	0.75	0.43	0.21	0.77	0.40	0.93	
200/310	0.95	0.53	0.26	0.95	0.50	0.92	

Figures in m

1) Measured on trench bottom

2) Dimension a₂ determined on the assumption that pre-formed bend components are not impeded by foundations, etc.

Distance from other supply lines

The ground temperature in the immediate vicinity of district heat pipes laid in the ground is higher than normal.

This can influence the transmission performance of electrical lines laid underground. Appropriate minimum distances are therefore required between the supply lines and the district heating pipes (also see VDE 0100 and VDE 0101).

Figure 1: Crossing lines/pipes

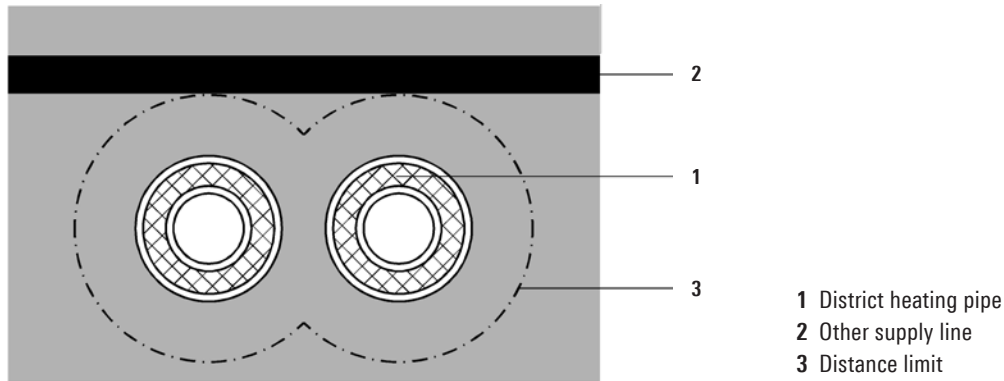

Figure 2: Parallel lines/pipes

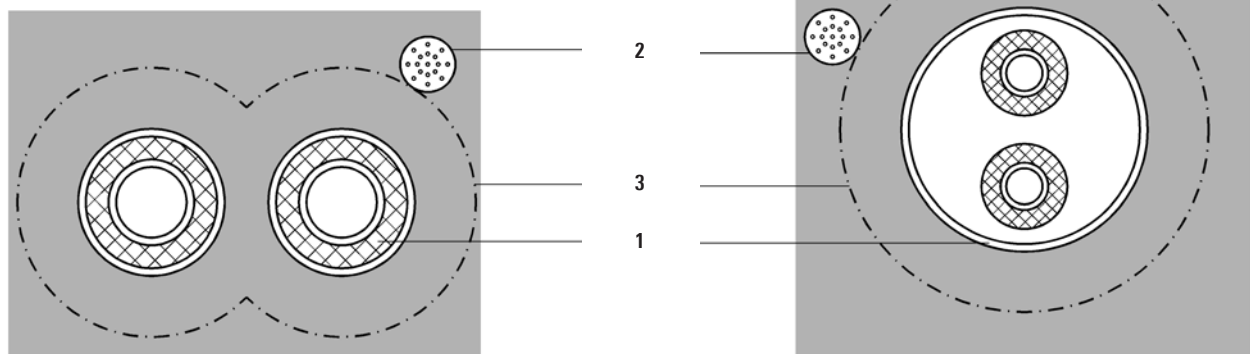

Table 1:
Minimum distance from crossing pipes/lines

Type of supply line	Minimum distance
1 kV, signal/measuring cable	0.3
10 kV or one 30 kV cable	0.6
Several 30 kV cables or cable above 60 kV	1.0
Gas and water pipes	0.2

Figures in m

Table 2:
Minimum distance from parallel lines/pipes

Type of supply line	Minimum distance Parallel routing Length	
	5 m	> 5 m
1 kV, signal/measuring cable	0.3	0.3
10 kV or one 30 kV cable	0.6	0.7
Several 30 kV cables or cable above 60 kV	1.0	1.5
Gas and water pipes	0.4	0.4

Figures in m